

# OUTLAW<sup>SS</sup>



You have purchased one of the highest quality electric bicycles available today. It is important you read this manual to understand your new bicycle. All riders including experienced non-electric bicycle riders should read this manual. This manual explains the functions of your new electric bicycle and details on performing basic maintenance. All riders must read the section on throttling prior to mounting the bicycle due to the nature of how to power the bicycle forward. Please take the time to register your new Prodeco Technologies electric bicycle for the warranty to take effect.

## USER GUIDE

Some of the content of this manual may differ from your bicycle depending on the options of the bicycle and what your dealer provided.

© 2013 PRODECO TECHNOLOGIES. All rights reserved. PRODECO TECHNOLOGIES and the PRODECO TECHNOLOGIES logo are trademarks of PRODECO TECHNOLOGIES. Printed in USA.

## DISCLAIMER FOR OFF ROAD USE ONLY

### **THE PURCHASER IS SOLELY RESPONSIBLE FOR DETERMINING THE RIDING SAFETY AND SUITABILITY OF THE OUTLAW ELECTRIC BICYCLE.**

This is a high performance trail riding electric bicycle. **USE AT YOUR OWN RISK.**

The Outlaw electric bicycle is equipped with a state-of-the-art high-power 750W motor equivalent to 1 horsepower and is strictly intended for OFF ROAD use. When using electric power, the Outlaw electric bicycle does not follow the Federal Guidelines for electric bicycles due in part to its 28mph top speed. It is NOT allowed on pedestrian walkways, bike paths or roadways when using electric power. Prodeco Technologies and its Authorized Dealer make no representation or warranty, express or implied that the use of the bicycle will comply with local, state, or Federal laws with regard to street legality, off road use or safety standards regarding motorized vehicles. The Outlaw electric bicycle can become bike path legal upon the removal of the battery. When not under electric power, the Outlaw electric bicycle follows the applicable federal, state, local laws, statues and ordinances of most states. It is the responsibility of the purchaser rider to familiarize themselves with their local laws regulating motorized bicycles. While not under power, the Outlaw electric bicycle performs similar to a traditional pedal power bicycle and can be pedaled as such.

Prodeco Technologies cannot control the challenges of off road terrain, riding abilities, riding habits and bicycle repairs and maintenance by the purchaser. The Outlaw electric bicycle is not designed for extreme riding conditions other than light trail riding. The purchaser is responsible to fully understand the capabilities and limitations of the bicycle as well as their riding abilities. The purchaser is also responsible to understand and obey all applicable federal, state, local laws, statutes and ordinances before operating their Outlaw electric bicycle.

The purchaser further understands, recognizes and agrees that the appropriateness of the Outlaw electric bicycle for a particular application is solely the purchaser's responsibility and that the purchaser is not relying on Prodeco Technologies or its Authorized Dealers regarding suitability of use. The purchaser agrees to indemnify and hold harmless Prodeco Technologies and its Authorized Dealers from any claim, action or demand outside of the limited warranty arising out of an incident in regards to the purchaser's use of the Outlaw electric bicycle.

PRODECO TECHNOLOGIES AND ITS AUTHORIZED DEALERS SHALL NOT BE LIABLE FOR AND HEREBY EXCLUDES ANY AND ALL INDIRECT, INCIDENTAL, SPECIAL OR CONSEQUENTIAL DAMAGES RELATING THE USE OF THE OUTLAW ELECTRIC BICYCLE COVERED BY THIS DISCLAIMER. PURCHASER HEREBY RELEASES AND FOREVER WAIVES AND DISCHARGES PRODECO TECHNOLOGIES AND ITS AUTHORIZED DEALERS FROM ANY AND ALL ACTIONS, INCLUDING BUT NOT LIMITED TO ANY ACTION, COVENANTS, CLAIMS, DEMANDS OR BODILY INJURIES, DEATH, COST OR LOSSES, DAMAGES TO THE BICYCLE, ANY PERSON OR ANY OTHER PROPERTY DAMAGE, HOWEVER ARISING, WHICH MAY HAVE BEEN OR MAY BE SUSTAINED BY, OR IN ANY WAY ARISING OUT OF, CONNECTED WITH OR RESULTING FROM THE RIDING OF THE OUTLAW ELECTRIC BICYCLE.

**Before operating the Outlaw electric bicycle or any bicycle, always utilize safety gear.**

## Table of Contents

<b>1) Chapter 1: Introduction</b>	<b>5</b>
a. About this manual	5
b. Important notices	5
c. General warning	5
d. A special note to parents	6
<b>2) Chapter 2: Getting Started</b>	<b>6</b>
a. Unpacking your box	6
b. Contents of the box	6
c. A guideline of your Outlaw tool set	6
d. Registering your new bike	6
e. Familiarize yourself with your bicycle's parts	7
<b>3) Chapter 3: Basic Instructions</b>	<b>7</b>
a. Bicycle fit	7
b. Adjusting the saddle	8
c. Installing the handlebar and stem	9
d. Your local electric bicycle and bicycle laws	9
e. Safety first	10
f. Mechanical safety check	10
g. Before your first motorized ride	11
h. First motorized ride	11
i. Riding an electric bicycle	11
j. Using your throttle	11
k. Using your brakes	11
l. Pedaling	12
m. Shifting gears	12
n. Watching for obstacles around you	12
o. Safe riding in various conditions	12
p. Charging your battery	12
<b>4) Chapter 4: Safety</b>	<b>13</b>
a. The basics	13
b. Riding safety	13
c. Wet weather riding	14
d. Reflectors	14
e. Night riding	14
f. Adding accessories	14
<b>5) Chapter 5: Perfect Fit and Ride</b>	<b>14</b>
a. The basics	14
b. Frame size	15
c. Recommended sizing	15
d. Control position adjustments	15
e. Brake lever adjustments	15
f. Suspension fork adjustment	16
<b>6) Chapter 6: Tire, Tube, Wheel or Axle Repair</b>	<b>16</b>
a. Removing the rear motor wheel	16
b. Installing the rear motor wheel	16
c. Removing and installing the front wheel	17
d. Replacing a tube or tire	17
<b>7) Chapter 7: Maintenance and Replacement</b>	<b>18</b>
a. Keeping your bike clean	18
b. Avoid scratching your bike	19
c. Brake pad bed-in process	19
d. Brake pad replacement	20
e. Derailleur adjustments	21
f. Wheel check	22
g. Lubricating	22
h. Crankset	22
i. Headset	22
j. Maintenance schedule	23
k. Torque specifications for common parts	23

<b>8) Chapter 8: Battery Management .....</b>	<b>24</b>
a. About your battery .....	24
b. Removing the battery .....	24
c. Installing and locking the battery .....	25
d. Charging the battery .....	25
e. Storing the battery .....	26
f. Battery power indicator .....	26
g. Battery replacement .....	26
h. Battery disposal .....	26
<b>9) Chapter 9: Electrical Components .....</b>	<b>26</b>
a. HUB motor .....	26
b. Brushless hall sensor controller .....	27
c. Wiring harness .....	27
d. Throttle .....	27
<b>10) Chapter 10: Warranty Service and Repair .....</b>	<b>28</b>
a. 2 year limited warranty .....	28
b. Registering your bike .....	29
c. Serial numbers and where to find them .....	29
d. Registration card .....	29
e. Part replacement procedure .....	30
f. Contacting Prodeco Technologies .....	30
<b>11) Chapter 11: Specifications .....</b>	<b>30</b>
<b>12) Chapter 12: Parts .....</b>	<b>31</b>

## OPERATIONAL INSTRUCTIONS

### Chapter 1: Introduction

Prodeco Technologies thanks you for your purchase of your new Outlaw. Your bicycle is a high quality and environmentally friendly light electric vehicle. This manual will serve to provide you with the information needed to operate, maintain and enjoy it safely. Your electric bicycle should provide you with years of healthy enjoyment provided you follow these steps.

For technical questions or customer service, please contact PRODECO TECHNOLOGIES at 800.943.6190 or e-mail us at [service@prodecotech.com](mailto:service@prodecotech.com).

#### a) About this manual

To prevent serious injury to yourself and others, and to prevent damage to the bicycle please read and understand these instructions completely before operating your Prodeco Technologies Outlaw. Your new bicycle is a powerful and reliable electric bicycle. You should use caution and care while getting accustomed to your bicycle's riding characteristics. The following manual will provide basic instructions regarding your bicycle's care and maintenance, battery management, operating procedures, and other important information. You should read it thoroughly before riding your new bicycle for the first time. If you have any questions that are not answered in this manual, contact your local authorized Prodeco Technologies dealer or you can call customer service at 800.943.6190.

#### b) Important notices

- Always remove the key from the battery when your bicycle is not in use, replacing a component or performing maintenance.
- Make sure your electric bicycle is properly fitted to you as described in Chapter 3 "Basic Instructions".
- Perform the mechanical safety check described in Chapter 3 "Basic Instructions" section f "Mechanical safety check" before each ride.
- You should ride your Outlaw as a traditional bicycle under pedal power prior to riding under motor power for the first time. This will allow for the familiarization of how your Outlaw rides and balances.
- When riding under power for the first time, press the variable throttle very slowly only after pedaling to a slow speed to understand the strength of the front motor's performance and grip on the road surface.
- Always apply full front & rear brake lever pressure when attempting to mount or dismount the bicycle.
- When attempting to mount or dismount the bicycle, the key should be in the off position on the battery.
- Please read the battery pack and detailed charging instructions found in Chapter 8 "Battery Management" before charging the battery pack for the first time.
- You should fully charge the Li-ion LiFEPO4 battery according to the charging instructions before your first ride.
- You should always fully charge your Li-ion LiFEPO4 battery every 8 miles regardless of the amount of small trip distances.
- You should always fully charge your Li-ion LiFEPO4 battery pack after each round trip ride exceeding 4 miles.
- Always store the battery pack in a cool and dry place.
- During periods of prolonged storage, the battery pack should be charged at least once every 6 months at a minimum of 60% or every 3 months at 40%. Do not charge higher than 60% when storing.
- Your Outlaw can be ridden as a traditional bicycle; it is strongly recommended that you also assist with pedaling when riding which can greatly increase the distance between battery charges.
- When riding under power, you can enhance distance in between charges by holding the throttle at 10% below full throttle.
- When riding under power, add as much non-powered coasting (similar to traditional pedaling) by releasing the throttle and allowing the bicycle to freely coast under its own momentum. This will greatly increase the distance between charges.
- Familiarize yourself with throttling (10% below full), pedaling and momentum coasting to optimize the distance being available per charge. If planning a long trip, applying a combination of the 3 distance enhancing methods mentioned above will allow for an uninterrupted power supply for the entire ride.

#### c) General warning

Like any sport, bicycling involves the risk of injury and damage. By choosing to ride a bicycle, you assume the responsibility for that risk, so you need to know — and to practice — the rules of safe and responsible riding and of proper use and maintenance. Proper use and maintenance of your bicycle reduces risk of injury.

This Manual contains many "Warnings" and "Cautions" concerning the consequences of failure to maintain or inspect your bicycle and of failure to follow safe cycling practices.

 **WARNING:** *This image followed by the word WARNING indicates a potentially hazardous situation that, if not avoided, could result in serious injury or death.*

 **CAUTION:** *This image followed by the word CAUTION indicates a potentially hazardous situation, which, if not avoided, may result in minor or moderate injury, serious, damage to the bicycle or the voiding of your warranty or is an alert against unsafe practices.*



Many of the Warnings and Cautions say, “you may lose control and fall”. Because any fall can result in serious injury or even death, we do not always repeat the warning of possible injury or death. Because it is impossible to anticipate every situation or condition that can occur while riding, this Manual makes no representation about the safe use of the bicycle under all conditions. There are risks associated with the use of any bicycle which cannot be predicted or avoided, and which are the sole responsibility of the rider.

d) A special note to parents

The Prodeco Technologies Outlaw is intended for use by adult riders only and not children. Many state laws require electric bicycle riders to be a minimum age of 16 with some states having minimum ages set at 18 years old (at the time of the writing of this manual). As a parent or guardian, you are responsible for the activities and safety of your minor child including the following of your state and local laws in regards to the riding of an electric bicycle by a minor (under the age of 18). That includes, if your state allows a minor to ride, making sure that your minor child can safely ride and control all of the operations of the bicycle, and fully understands all warnings and cautions as indicated in this User Guide. Please read on if you have determined that your minor child can legally and safely ride and control all of the operations of the bicycle. That includes making sure that the bicycle is properly fitted to the child; that it is in good repair and safe operating condition; that you and your child have learned and understand the safe operation of the bicycle; and that you and your child have learned, understand and obey not only the applicable local motor vehicle, bicycle and traffic laws, but also the common sense rules of safe and responsible bicycling. As a parent or guardian, you should read and understand this manual. Before letting any child ride the Outlaw or any of Prodeco Technologies electric bicycles, review with them all warnings and cautions; as well as the information on the proper usage of your battery pack, charger and bicycle. You must first confirm the laws, rules and regulations regarding electric bicycles in your state, city and local municipality.

 **WARNING:** *riders of the Outlaw must always wears an approved bicycle helmet and safety gear when riding.*

## Chapter 2: Getting Started

 **CAUTION:** *If you have purchased your bicycle by mail order or through a sales channel whereas your new Outlaw is still in the box, it is recommended you read Chapter 3 “Basic Instructions” section g “Before your first ride” prior to your first ride. There may be additional adjustments required due to shipping by the freight carrier.*

a) Unpacking your box

Your Outlaw arrives fully assembled in it's box and only requires the installation of the handlebar. You can learn how to install the handlebar in Chapter 3 “Basic Instructions” section c “Installing the stem and handlebar”.

The Outlaw has been fully tested and adjusted prior to being packed in the Heavy Duty double wall box with a form fitting interior support system. To remove the Outlaw from it's box, open the top flap of the box and remove the top protection insert. Place one hand under the front portion of the frame and the other hand under the center of the frame. Pull up slowly and the bicycle will lift out of the box. Remove the additional inserts (if attached to bicycle) and set the bicycle down by balancing the bicycle on both wheels.

b) Contents of the box

Check the contents of your box. Your new Outlaw should include the following items in the box or your dealer should have included these items with your purchase:

- Outlaw electric bicycle
- Gyes Leather saddle (attached to seat post)
- Prodeco Tech 48V9Ah LiFePO4 Battery
- 48V LiFePO4 charger & power cable
- 2 keys
- Multi-use nickel plated tool set
- 3 Arm Y tool (4, 5 & 6mm)
- 2 cable ties (for future use)

c) A guideline of your Outlaw tool set

The Outlaw includes a multi-use tool set. This tool set includes all the tools necessary to make adjustments and service your new bicycle. The only additional tool you will ever need is an 18mm wrench to remove the front wheel. All other tools are included with the tool kit. The tool kit includes the following tools:

- Philips Screwdriver
- Flat Head Screwdriver
- 2mm Hex Key
- 2.5mm Hex Key
- 3mm Hex Key
- 4mm Hex Key (multi & Y)
- 5mm Hex Key (multi & Y)
- 6mm Hex Key (multi & Y)
- 8mm Hex Key
- Torx 25
- Chain Pin Removal
- Spoke Nipple Wrenches

d) Registering your new bike

For the warranty to take effect, you must register your new bicycle. Registration of your electric bicycle is the only way we can acknowledge and verify the established owner. Your bicycle has 3 individual and unique serial numbers (frame, motor and battery). Each serial number must be registered when filling out the registration form. The serial number on the frame is located under or on top of the crank/bottom bracket portion of the frame. The serial number for the motor is found on the motor's side. The serial number for the battery is located on the barcode label adhered to the underside of the battery. These numbers should be recorded and registered in case of warranty issues or theft. Please review Chapter 10 “Warranty Service and Repair” section c “Registering your bicycle” on how to register your Outlaw. You can register by either filling out the online registration form at [www.prodecotech.com/register-your-bike/](http://www.prodecotech.com/register-your-bike/) or by sending the registration card found in Chapter 10 “Warranty Service and Repair” section d “Registration card”.

e) Familiarize yourself with your bicycle's parts



<b>A</b> Hub Motor	<b>G</b> Saddle	<b>M</b> Handlebar
<b>B</b> 8 Speed Freewheel	<b>H</b> Seat Post	<b>N</b> Adjustable Stem
<b>C</b> Derailleur	<b>I</b> Seat Clamp	<b>O</b> Fork Adjustment
<b>D</b> Sliding Battery	<b>J</b> Water Bottle Mount	<b>P</b> Headset
<b>E</b> Battery Strut	<b>K</b> Bottom Bracket	<b>Q</b> Disc Brake
<b>F</b> Battery Mount	<b>L</b> Crankset	<b>R</b> 20mm Thru Axle

## Chapter 3: Basic Instructions

### a. Bicycle Fit

It is very important your Outlaw is properly adjusted for comfort and to avoid the possibility of losing control while riding. The saddle will adjust to allow riders from 5' 8" to 6' 6" to set the proper measurement allowing for a safe and comfortable riding position. If you plan to use your electric bicycle also as a traditional pedal bicycle, it is recommended you adjust the saddle height to allow for a full leg extension when pedaling. The ball of your foot when resting on the pedal should only allow for a slight bend at the knee when seated. Please review the following points in determining how to make the correct adjustments. The subsequent sections will assist you with making these adjustments.

- 1) Is your bike adjusted to your size?
- 2) To check, see Chapter 5 "Perfect Fit and Ride". If your bicycle is not properly adjusted for you, you may lose control and fall.
- 3) Is the saddle at the right height? To check, see Chapter 5 "Perfect Fit and Ride" section a "Stand over height".
- 4) Are saddle and seat post securely clamped? A correctly tightened saddle will allow no saddle movement in any direction. See Chapter 3 "Basic Instructions" section b "Adjusting the saddle" for details.
- 5) Can you comfortably operate the brakes? If not, you have the ability to adjust their angle and reach. See Chapter 5 "Perfect Fit and Ride" section e "Brake lever height adjustments" for details.
- 6) Do you fully understand how to operate your new bicycle? If not, before your first ride, have your dealer or contact us to explain any functions or features that you do not understand after fully reading this manual.

b. Adjusting the saddle

You have the ability to adjust the height of your saddle instantly via the quick release clamp. There is also the ability to tilt the nose of the saddle up or down and adjust your riding position to be further or closer to the handlebar. The latter two require the use of the multi-use tool included with the purchase of your Outlaw. Please review the following details on adjusting your saddle.

To adjust the height of the saddle or remove the seat post, no tools are required. The quick release lever is opened by pulling the lever away from the seat tube allowing for the seat tube clamp to loosen the grip around the post. This will allow you to raise or lower the saddle to the desired height. There is a minimum insertion line on the seat post which must be followed and you must not extend the seat post past this mark. It is also important the seat tube clamp is tightened sufficiently around the seat post for it not to slide downwards after the quick release lever is closed. This can be accomplished by tightening the quick release nut clockwise which is located on the opposite end of the quick release lever.



**▲ WARNING:** *The seat post includes a minimum insertion mark. It is important you do not allow the seat post to be clamped below this mark. This mark must be inserted into the frame pass the top of quick release clamp. If clamping below this mark, it can cause the seat post to break, failure to follow this warning could result in serious injury or death.*

**● CAUTION:** *The seat tube quick release clamp must be checked for tightness to ensure the saddle will not accidentally slide into the seat tube when riding. This can cause a rider to lose balance and may result in a fall.*

To tilt the nose of your saddle upwards or downwards, you will need to use the 5mm hex key included with your multi-use tool kit that came with your bicycle. The saddle mounting clamp attaches the saddle to the seat post via a front and rear barrel nut and bolt. To bring the nose of the saddle down, loosen the rear bolt by 1 full counter clockwise rotation and tighten the front bolt by 1 full clockwise rotation. Check for comfort and if the nose is still too high, attempt the above step again. Continue to adjust by repeating the step above until the desired nose height is established. If you prefer to raise the nose, you can follow the above step but in the opposite direction (loosen the front bolt counter clockwise 1 rotation and tighten the rear bolt clockwise 1 rotation). **All bolts should be tightened to 140 in\*lb.** (SEE PHOTOS)

**● CAUTION:** *The saddle mounting clamp front and rear barrel nut and bolt must remain tight at all times. Test saddle for looseness or play in the rotation of the nose. If saddle is loose, tighten the bracket bolts to ensure the saddle will not accidentally rotate up or down when riding. Both bolts should be tightened to 140 in\*lb. If loose, this can cause a rider to lose balance and may result in a fall.*

Your saddle can be adjusted to be closer or further away from the steering tube/handlebar (you will need to use the 5mm hex key included with your multi-use tool kit). This adjustment is minimal but allows a 7.5mm adjustment in either direction from center mount (15mm total, close to 5/8"). To adjust the saddle closer or further, you must loosen the rear and front barrel nut and bolt set which connects the saddle rails to the saddle mounting clamp located at the top of the seat post. Loosen both bolts by rotating 2 times counter clockwise each. This should allow for sufficient looseness to slide the saddle rails in either direction on the saddle mounting clamp. You must not allow the edge of the saddle mounting clamp to meet with the saddle rail bends. The edge of the clamp must be a minimum of 5mm from the saddle rail bends. Upon establishing the correct position, tighten the saddle mounting clamp bolts 2 times in clockwise direction. Check for tightness of bolts and continue turning if loose. **All bolts should be tightened to 140 in\*lb.** (SEE PHOTOS)

**● CAUTION:** *The edge of the saddle mounting clamp must have a minimum of 5mm of clearance from the saddle rail bends. If the edge of the clamp is mounted to close the saddle rail bends and the rider does not position themselves properly on the saddle, this could result in the rails becoming unstable due to the leverage of the riders weight. The rails can bend and can cause a rider to lose balance and may result in a fall.*





c. Installing the handlebar and stem (SEE PHOTOS)

The handlebar of the Outlaw is not secured to the stem when shipped. The handlebar is temporarily attached to the frame with shipping ties. Using scissors, cut the ties to free the handlebar from the frame. You will need to place the center of the handlebar into the stem's concaved center and attach the handlebar clamp plate to the stem. There are 4 stem binder bolts which tighten the plate to the stem, securing the handlebar in place. You will also want to rotate the handlebar to a comfortable riding position prior to your final tightening / torquing of the stem binder bolts. The stem binder bolts require torquing of a minimum 60 lb\*in. The brake levers, throttle and shifter positions can be adjusted afterwards for proper control.

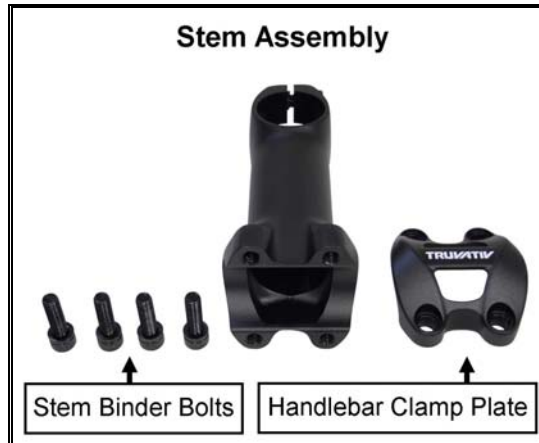

**⚠ WARNING:** *The handlebar should be properly rotated for comfort and control. Loosen the 4 stem binder bolts and rotate the handlebar downwards or upwards to a preferred riding position. Tighten stem binder bolts to 60-90lbs\*in.*

d. Your local electric bicycle and bicycle laws (**The OUTLAW does not qualify due to its 28mph speed**)

Your new Outlaw does not follow the federal guidelines due to its 28mph speed. Without battery power, the Outlaw can be traditionally pedaled as a standard bicycle within most states and be allowed on bicycle pathways. However, electric bicycle laws change often and you are responsible to confirm legal status of the riding of your electric bicycle on bicycle pathways. Below is a reference section on the USA electric bicycle federal guidelines:

**Electric Bicycle Laws** (please contact your local transportation department for the specific laws in your state and city regarding riding electric bicycles on bike pathways)

**Prodeco Technologies offers the following information as guidance and does not guarantee or assure riders they are following the rules and regulations of their state.**

Electric bicycle laws may vary by state to state with most states following the classification of that by the CPSC (Consumer Product Safety Commission), DOT & NHSTA. Further, the US NHSTA (National Highway Traffic Safety Administration) defines low-speed electric bicycles (under 20mph) also as consumer products and not Motor Vehicles for safety standards. The NHSTA adheres for the most part to the CPSC guidelines. We included reference below on how electric bicycles are perceived by the Federal Government's most important agencies. We do believe new regulation and rules will apply in the future upon the electric bicycle becoming one of the standard forms of transportation for the masses. Prodeco Technologies will continue to follow new rules and guidance set forth by these agencies, always welcoming and adhering to the guidelines they feel are required to assure safety for the electric bicycle rider.

**On October 22, 2008, the Federal Highway Administration (FHWA) updated the Bicycle and Pedestrian Provisions of Federal Transportation Legislation to make technical corrections and clarifications.**

Below are the important updates reflecting electric bicycles:

**Motorized Vehicle Use:** In general, motorized vehicles are not permitted on non-motorized trails and pedestrian walkways funded under Title 23. Exceptions to this general rule exist for maintenance vehicles; motorized wheelchairs; when State or local regulations permit, snowmobiles; and electric bicycles (weighing under 100 pounds and a top speed of less than 20 miles per hour); "and such other circumstances as the Secretary deems appropriate" (except the Recreational Trails Program which specifically provides funds for motorized trails). In 2008, FHWA developed a Framework for Considering Motorized Use on Non-motorized Trails and Pedestrian Walkways to implement the "other circumstances" provision.

**Framework for Considering Motorized Use on Non-motorized Trails and Pedestrian Walkways under 23 U.S.C. § 217**

The purpose of this document is to provide guidance to Federal Highway Administration (FHWA) division offices and a consistent framework for determining when to permit an exception for motorized use on non-motorized trails and pedestrian walkways under 23 U.S.C. § 217(h)(5). The relevant legislation reads as follows:

**23 U.S.C. § 217. Bicycle Transportation and Pedestrian Walkways** (h) Use of Motorized Vehicles.--Motorized vehicles may not be permitted on trails and pedestrian walkways under this section, except for-- (1) maintenance purposes; (2) when snow conditions and State or local regulations permit, snowmobiles; (3) motorized wheelchairs; (4) when State or local regulations permit, electric bicycles; and (5) such other circumstances as the Secretary deems appropriate.

(j) Definitions.--In this section, the following definitions apply:

(2) **Electric bicycle.**--The term "electric bicycle" means any bicycle or tricycle with a low-powered electric motor weighing under 100 pounds, with a top motor-powered speed not in excess of 20 miles per hour.

(4) **Wheelchair.**--The term "wheelchair" means a mobility aid, usable indoors, and designed for and used by individuals with mobility impairments, whether operated manually or motorized.

## HR 727

### SECTION 1, CONSUMER PRODUCT SAFETY ACT

The Consumer Product Safety Act (15 U.S.C. 2051 et seq) is amended by added at the end of the following:

#### LOW-SPEED ELECTRIC BICYCLES

SEC. 38.(a) Notwithstanding any other provision of law, low-speed electric bicycles are consumer products within the meaning of section 3(a)(1) and shall be subject to the Commission regulations published at section 1500.18(a)(12) and part 1512 of title 16, Code of Federal Regulations.

(b) For the purpose of this section, the term 'low-speed electric bicycle' means a two or three-wheeled vehicle with fully operable pedals and an electric motor of less than 750 watts (1 h.p.), whose maximum speed on a paved level surface, when powered solely by such a motor while ridden by an operator who weighs 170 pounds, is less than 20 mph.

(c) To further protect the safety of consumers who ride low-speed electric bicycles, the Commission may promulgate new or amended requirements applicable to such vehicles as necessary and appropriate.

(d) This section shall supersede any State law or requirement with respect to low speed electric bicycles to the extent that such State law or requirement is more stringent than the Federal law or requirements referred to in subsection (a).

#### SEC. 2. MOTOR VEHICLE SAFETY STANDARDS.

For purposes of motor vehicle safety standards issued and enforced pursuant to chapter 301 of title 49, United States Code, a low-speed electric bicycle (as defined in section 38(b) of the Consumer Product Safety Act) shall not be considered a motor vehicle as defined by section 30102(6) of title 49, United States Code.

#### Local Bicycle Laws

Most states have their own set of bicycle laws regarding traditional pedal powered bicycles. With most states recognizing electric bicycles as traditional pedal powered bicycles you must know the applicable laws for your area. Your Department of Transportation or Cycle Clubs in your area will have the details involving riding a bicycle in your area and your city's bike pathways. Requirements for riding change depending upon your location. Most cities require LED lights, hand signals, riding on the correct side of the road, riding behind and not parallel to other cyclist, etc...

##### e. Safety first

It is important you follow your local bicycle laws but also it is important you ride safely. Below are examples of understanding how to ride your new Outlaw safely.

- Always wear an approved helmet when riding your bike and follow the helmet manufacturer's instructions for fit, use and care of your helmet.
- Do you have all the other required and recommended safety equipment for your area? It's your responsibility to familiarize yourself with the laws of the areas where you ride, and to comply with all applicable laws.
- Do you know how to correctly check your wheel axle? Do you understand proper braking techniques? Is your saddle properly adjusted? How do you power your new electric bicycle? These are all questions you should have the answers to prior to riding for the first time. This USER GUIDE will answer most of the questions you have in regards to your new bicycle and assist you in ensuring your electric bicycle remains safe to ride. You should first read the USER GUIDE in its entirety and familiarize yourself with your new bicycle prior to riding.
- For further safety guidelines, please read Chapter 4: Safety

##### f. Mechanical safety check

Check the condition of your bicycle before every ride.

- **Nuts, bolts and straps:** Make sure nothing is loose. Lift the front wheel off the ground by two or three inches then let it bounce on the ground. Anything sound, feel or look loose? Do a quick visual and tactile inspection of the whole bike. Are there any loose parts or accessories? If so, secure them. If you're not sure, ask someone with bike experience to check.
- **Tires and Wheels:** Make sure tires are correctly inflated, see Chapter 6. Check by placing one hand on the saddle and the other on the intersection of the handlebars and stem, then bounce your weight on the bike while looking at tire deflection. Compare what you see with how it looks when you know the tires are correctly inflated; and adjust if necessary. Are the tires in good shape? Spin each wheel slowly and look for cuts in the tread and sidewall. Replace damaged tires before riding the bike. Spin each wheel and check for brake clearance and side-to-side wobble. If a wheel wobbles side to side even slightly, or rubs against or hits the brake pads, take the bike to a qualified bike shop to have the wheel trued.
- **Brakes:** Check the brakes for proper operation. Squeeze the brake levers. Are the brakes properly releasing? All control cables seated and securely engaged? Do the disc brake pads grasp the rotors within an inch of brake lever movement? Can you apply full braking force at the levers without having them touch the handlebar? If not, your brakes need adjustment. Do not ride the bike until the brakes are properly adjusted.
- **Quick Releases:** Make sure seat post, rear axle & frame quick release levers are properly adjusted and all are in the locked position.
- **Handlebar and saddle alignment:** Make sure the saddle and handlebar stem are parallel to the bike's center line, clamped and bolts tightened enough so that you can't twist them out of alignment. If not, align and tighten them.
- **Handlebar ends:** Make sure the left handlebar grip and right throttle grip are secure and in good condition. If not, replace them.
- **Battery Pack Attachment:** Ensure your battery pack is firmly attached to your bicycle before riding. To test battery attachment, pull up on the battery pack handle after battery is locked in place. If attached properly you will not be able to slide the battery off the bike. If not, the battery pack will slide off the bike.

 **CAUTION:** *The braking of your bicycle is one of the highest concerns in safety. Proper brake lever mounting and cable adjustment is crucial for your brakes to work properly.*

 **WARNING:** *All Quick release levers must be closed and the clamps or axles tight. One loose quick release lever can cause the rider to lose control and cause serious injury or death.*

 **WARNING:** *Loose or damaged handlebar grips or extensions can cause you to lose control and fall. Unplugged handlebars can cut your body, and can cause serious injury in an otherwise minor accident.*

g. Before your first motorized ride

Before your first ride study this manual in its entirety. Make sure you are comfortable and confident when sitting on the bicycle. If an adjustment does not feel right or something feels loose, check to ensure you are properly fitted to the bike and do a mechanical safety check as explained in the previous section. Make sure you fully charge your battery with the appropriate charger included with your bicycle. Be sure to firmly attach the battery to the bicycle. Try to slide the battery off the bike by the battery handle to confirm proper installation. Read Chapter 3, section h. (the following section) again.

h. First motorized ride

When you buckle on your helmet and go for your first familiarization motorized ride on your new bicycle, be sure to pick a controlled environment, away from people, other cyclists, obstacles or other hazards. Ride to become familiar with the brake levers against throttling, variable throttle performance while pedaling your new bike and not pedaling. The first motorized ride should be initially pedaling and then slowly pressing down on the throttle to feel the engagement of the HUB motor. Familiarize yourself with the sensation of power.

- Familiarize yourself with the braking action of the bike. To test the brakes at slow speed, shift your weight towards the rear and gently apply the brakes, rear brake first. Sudden or excessive application of the front brake could pitch you over the handlebars. Applying brakes too hard can lock up a wheel, which could cause you to lose control and fall (see section k.).
- Your bike has a front suspension system, familiarize yourself with how the suspension responds to braking application and rider weight shifts.
- Check out the handling and response of the bike; and check the comfort.
- If you have any questions, or if you feel anything about the bike is not as it should be, take the bike back to your dealer for advice or contact Customer Service at Prodeco Technologies.

i. Riding an electric bicycle

Riding an electric bike is similar to riding a non-electric bike but there are some differences to note. An electric bike is slightly heavier and requires more time to stop due to higher traveling speeds. Your bike is also equipped with a powerful motor that provides a noticeable boost when starting from a stop. The boost is exhilarating, but you must be comfortable with the sensation before riding in crowded or congested areas. To maximize battery life, assist with pedaling, engage throttle to 90% or less and add considerable coasting with no throttle to your riding. Your battery is a finite resource and proper riding techniques will prolong its distance per charge.

j. Using your thumb throttle (SEE PHOTO)

The variable throttle on your Outlaw was designed to allow you the ability to choose the speed to ride at and determine the amount of torque off the line. The throttle operates similar to an automobile; the pressing of the thumb throttle mimics the depressing of the accelerator. The throttle is located on the right side grip and considered a variable thumb throttle. The grip itself does not twist. Using your thumb, press the throttle lever down to propel the bike forward. A thumb throttle is used to avoid accidentally twisting a grip when mounting and dismounting the bicycle. Your throttle also includes a Power ON and Power OFF button. It is the red button located underneath the LED lights. Depressing the button activates the throttle and pressing the button out will deactivate the throttle. The ON / OFF button is for further safety. There is also an LED set of lights which assist in determining the amount of battery storage capacity remaining. This is discussed in further detail later in the manual. Throttling is an important factor with any electric bicycle and the distance of traveling available per charge. The higher the speed, the less distance per charge, hard accelerations also decrease distance per charge. Multiple stops and take offs in a ride also affect the range of distance per charge. It is recommended you become accustomed to your style of riding and adjust the style depending on distance needed per charge. For example: if you are planning a short local trip, full throttle at takeoff and top speed will not be an issue due to your ability to be able to recharge the battery prior to the next trip. If you are planning a longer trip, 8 miles or more, it is suggested you add pedaling, hold throttle back 10% and whenever possible allow the bicycle to coast under no power. Coasting under no power is similar to riding a traditional pedal powered bicycle. When riding, a rider will pedal for a few seconds and then stop pedaling, allowing the bike to coast with no power being used. This will greatly increase your distance between charging.



k. Using your brakes

Your Outlaw is equipped with a high performance Avid Elixir 5 Hydraulic Disc Brake system. The Elixir 5 front and rear disc brakes allow your new Outlaw to stop quickly and accurately. Oversized Avid HS "Heat Shedding" stainless steel disc rotors were utilized for the axles for increased heat dissipation. Hydraulic brakes are self-adjusting. No adjustments are required once the calipers are properly installed utilizing Avid's Tri Align spherical and concave CPS bolt system. When properly mounted, the Outlaw high performance disc brake system offers tremendous stopping power. Prior to leaving the factory, the Outlaw brakes were properly mounted and tested. Disc brakes however do require a bed-in process which occurs naturally after 20-40 stops. It can be sped up by following the bed-in guidelines detailed in Chapter 7 "Maintenance and Replacement", section c "Brake pad bed in".

When braking, both brake levers should be applied simultaneously. Your left brake lever manages your front brake and your right brake lever manages your rear brake. You should become accustomed to the stopping power of each brake (front & rear). Test each brake separately in a controlled environment for their ability to stop the bicycle. Front brakes when locked can cause the rear wheel to come off the ground and the rider can be thrown off the bicycle. In emergency situations, apply pressure to each brake lever, shift your weight to the back of the bicycle and only attempt to use full force on the front brakes when the bicycle is not stopping quickly enough. Always keep a safe distance between other vehicles, pedestrians and other riders.

**⚠ WARNING: Locking the front wheel during braking can cause the rear wheel to lift off the ground and throw the rider off the bicycle. Both brake levers should be applied simultaneously. In an emergency situation shift your weight to the back of the bicycle. Locking the front wheel can cause the rider to lose control, be thrown off the bicycle and cause serious injury or death.**



### I. Pedaling

Pedaling your Outlaw is the same as pedaling a traditional bicycle. It is recommended you add pedaling to the power of the bicycle to enhance the distance per charge. The Outlaw is a 8 speed bicycle and has the ratio of a 42T front chain ring (sprocket) against a 11-28T rear freewheel which is designed to offer an easy pedaling pace at any speed from 1 MPH to 18 MPH. It is recommended on steep inclines, the rider utilizes the throttle to assist in powering the bicycle up the incline while simultaneously dropping the bicycle to a lower gear. If a rider's style of riding is throttle only with no pedaling, distance per charge will be decreased. Upon a steep incline, the rider is required to assist the motor by pedaling to power up the incline.

### m. Shifting gears (SEE PHOTO)

The shifting of gears is required to change the ratio of the rotation of pedaling to allow more or less torque and lower or higher speeds according to one complete rotation of the crank set. If requiring more torque, you will shift to a larger rear sprocket for a higher rotation of pedaling to a lower speed of the rear wheel. To switch to a larger rear sprocket, you will need to shift to a lower gear. Gear 1 is the largest sprocket which is 28 Teeth and your lowest gear. One full crank rotation creates a 1.57 turn of the rear wheel. For higher speeds from less rotation of the crankset on flat pathways, you will shift to a smaller rear sprocket for a higher wheel rotation to a lower crankset speed. To shift to a smaller sprocket, you will need to shift to a higher gear. Gear 8 is the smallest sprocket with 11 Teeth and your highest gear. One full crank rotation creates a 3.8 turn of the rear wheel.

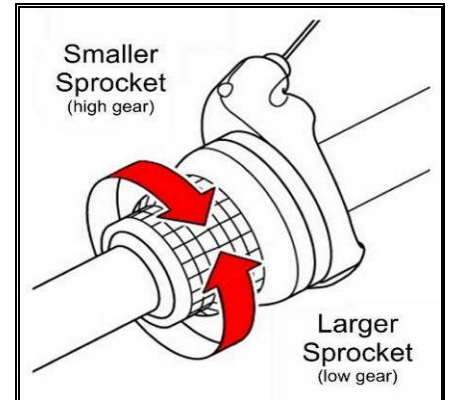

### n. Watching for obstacles around you

Your new Outlaw travels at higher speeds than most riders are accustomed to; as compared to pedaling a traditional bicycle. It is very important you are aware of your surroundings and obstacles which may appear near you. You must watch the path surface you are traveling on which could cause the tires to slip or cause a flat. Examples are soft shoulders, rocks, holes, uneven paths, grates, construction sites. Due to the higher rate of speed when riding under motor power versus pedaling, objects will advance into your path at a faster rate. Pay attention to other riders in your area, vehicles, motorcycles, pedestrians, poles, cross paths and signs to name a few. The Outlaw resembles a traditional bicycle and people walking, driving or standing may not realize you are on a motor powered vehicle and misjudge your traveling speed.

**⚠ WARNING: *Hitting a pot hole, soft shoulder or other road deviation may cause you to lose control, be thrown and cause serious injury or death.***

### o. Safe riding in various conditions

Riders may find themselves riding in a condition they did not plan on encountering. It is important your new Outlaw is maintained properly for optimum performance. Please read Chapter 7 on the details required to keep your electric bicycle at its best. An unexpected rain storm, snow flurry or night ride could arise during a day's trip and you should always be prepared. Please read Chapter 4 on Safety, so upon encountering an unexpected riding condition, you will be confident and ready.

### p. Charging your battery

The Outlaw's battery system is the safest and latest technology in Lithium Ion battery cells and was designed to be easily charged. Chapter 8 offers a detailed explanation on battery management but the following information is a basic guide in charging your battery. The battery is a removable device and can be charged on or off the bicycle. If removing the battery to charge it, please follow these instructions.

- Locate the key ignition on the battery and turn the key in a counter clockwise rotation to the "UNLOCK" position. You must push the key in to turn from the "OFF" position to the "UNLOCK" position.
- Grab the handle at the back of battery and carefully pull towards the back of the bicycle to slide off.
- The battery is now transportable and can be charged away from the bicycle when in "UNLOCK" position.

### For charging, please review the following instructions.

- Locate the RCA charging input at the front of the battery and open the charger input cover.
- Insert the charging plug from the charger into the battery's RCA charging input.
- Insert the charger's power cord into a wall outlet.
- The charger's LED light will light RED while the charger is charging the battery.
- The charger's LED light will light GREEN upon the battery being fully charged.
- There is also a battery indicator for checking a full charge. Press the indicator button to display the battery's energy storage. The indicator is located on top of the battery.
- Once the battery is fully charged, you should discontinue charging and remove the charger.
- Unplug the charger's power cord from the wall and remove the charging plug from the battery.
- You are ready to install the battery pack back onto your bicycle.
- To install the battery, first align the bottom of the battery with the battery base rail.
- Once aligned, slide the battery firmly into the battery base and until the battery base terminals insert into the battery's terminal outlets. The battery's locking slots must slide properly onto the mount's 3 metal tabs.
- Once the battery is properly slid into place, you can then turn the key to the "ON" position.
- The LEDs on the throttle in the "ON" position will display a charged battery's energy capacity.



## Chapter 4: Safety

The manual has detailed safety riding methods. In this chapter we will further discuss additional safety guidelines.

### a. The basics

Below is a safety guideline according to the CPSC (US Consumer Product Safety Commission) in regards to riding a bike. The Outlaw may only fall under traditional bike guidelines when not powered. If powered (battery installed), the Outlaw is not street or bike path legal and for off road riding only mainly due to speeds up to 28mph. Check your local bicycle laws regarding electric bicycles.

- Always wear a helmet to help prevent head injuries.
- Observe all traffic laws and signals, just as automobiles must do.
- Don't ride double or attempt stunts.
- Ride near the curb in the same direction as traffic.
- Find alternate routes, rather than ride through busy intersections and heavy or high-speed traffic.
- Walk -- don't ride -- your bicycle across busy intersections and left turn corners.
- Avoid riding in wet weather. When wet, handbrakes may require a long distance to stop.
- Avoid riding in the dark. If you do, be sure the bike is equipped with a headlight, a taillight and reflectors. Apply retro-reflective trim to clothing, or wear reflective vests and jackets.
- Avoid loose clothing or long coats that can catch in pedals or wheels. Leg clips or bands keep pants legs from tangling in the chain.
- Avoid crossing raised sewer grates.
- Regular maintenance is essential for safe riding. Refer to the maintenance recommendations. If you do not have basic mechanical skills, an authorized dealer should perform repairs and maintenance.
- Align (or "true") wobbly wheels for better control. Spokes also may need adjustment.
- Replace all missing, damaged, or worn parts; for example, brake pads, chainguards, chain links, spokes, screws and bolts, handlebar grips.
- Tighten and/or adjust loose parts.
- Periodically inspect frame, fork, spindles and other components for cracking.
- Parts should be adjusted to manufacturer's torque specifications.
- Inflate tires to recommended pressure, and replace worn tires.
- Lightly oil and clean moving parts. Keep oil off rubber.
- Keep bicycle indoors when not in use.

### b. Riding Safety

Below are guidelines according to the NHSTA (National Highway and Traffic Safety Administration) on bicycle safety. The Outlaw may only fall under traditional bike guidelines when not powered. If powered (battery installed), the Outlaw is not street or bike path legal and for off road riding only mainly due to speeds up to 28mph. Check your local bicycle laws regarding electric bicycles.

- **Protect Your Head: Wear a Helmet** - Never ride a bicycle without wearing a properly fitted helmet. Helmets are proven to be 85-88 percent effective in preventing traumatic brain injury, the primary cause of death and disabling injuries resulting from cycling crashes. Wear a helmet that meets the U.S. Consumer Product Safety Commission (CPSC) standard (see inside of helmet for presence of a label).
- **Assure Bicycle Readiness: Ensure Proper Size and Function of Bicycle** - Make sure the bicycle fits you: Stand over the top of the Outlaw bicycle – there should be minimum 3 inches of clearance from the frame bar. Seat height — as previously mentioned, with the ball of your foot on the pedal, the fully extended leg should have a slight bend. Check all parts of the bicycle to make sure they are secure and working well: The Handlebar should be firmly in place and turns easily. The wheels must be straight and secure; the quick release rear axle must be secured.
- **Stop It: Always Check Brakes Before Riding** - Always control your speed by using your brakes. Apply the rear brake slightly before the front brake. Always keep your brakes adjusted. If you cannot stop quickly, adjust your brakes. Review Chapter 7 "Maintenance and Replacement" section c "Brake adjustments" to adjust the brakes. When your hand brake levers are fully applied, they should not touch the handlebars. Ride slowly in wet weather and apply your brakes earlier, it takes more distance to stop.
- **See and Be Seen** - Wear clothes that make you more visible. Always wear neon, florescent, or other bright colors when riding a bicycle.
- **Avoid Biking at Night** - It is far more dangerous to ride a bicycle at night than during the day. The Outlaw requires LED lights for night time riding. If you must ride at night, you should also do the following: wear retro-reflective clothing or material, not just white or florescent, especially on your ankles, wrists, back, and helmet. Only ride in areas familiar to you. Brightly lit streets are best. Always assume you are not seen by a driver. Children should NOT ride at night.
- **Go With the Flow: The Safe Way is the RIGHT Way** - Ride on the right side in a straight, predictable path. Always go single file in the same direction as other vehicles. Riding against traffic puts you where motorists don't expect you. They may not see you, and may pull across your path, or turn into you.
- **Check for Traffic: Always Be Aware of the Traffic Around You** - Over 70 percent of car-bicycle crashes occur at driveways or other intersections. Before you enter any street or intersection, check for traffic. Always look left-right-left, and walk your bicycle into the street to begin your ride. If you are already in the street, always look behind you for a break-in traffic, then signal before going left or right. Watch for left or right turning traffic.

The Outlaw may only fall under traditional bike guidelines when not powered. If powered (battery installed), the Outlaw is not street or bike path legal and for off road riding only mainly due to speeds up to 28mph. Check your local bicycle laws regarding electric bicycles.

- **Learn Rules of The Road: Obey Traffic Laws** - Bicycles are considered vehicles. Bicyclists must obey the same rules as motorists. Read your State drivers handbook, and learn and follow all the traffic signs, laws, and rules for operating a vehicle on the road. Always signal your moves. Be courteous to pedestrians and other vehicle operators. *Never wear headphones* while riding as they impair your ability to hear traffic. Become familiar with the accommodations that are available for bicyclists in your area. These include bicycle lanes and routes as well as off-road paths. Take advantage of these whenever possible.
- **“Drive” with Care: Share the Road** - When you ride, consider yourself the driver of a vehicle and always keep safety in mind. Choose to ride in the bike lane, if available. If the roadway or bike lane is wide, ride to the right; if the lane is narrow, you may choose to ride in the middle of the lane. Take extra precautions when riding on a roadway. Bicycles are smaller than automobiles, and don't protect the operator like an automobile. You should: Make eye contact, smile, or wave to communicate with motorists. Courtesy and predictability are a key to safe cycling; be considerate and aware of motorists and pedestrians. Learn to anticipate their actions. Remember, pedestrians have the right of way; Ride far enough away from the curb to avoid the unexpected from parked cars (i.e. opening doors or drivers pulling out without checking); Keep control of your bicycle: look behind you while maintaining your bicycle in a straight path; be able to ride with one hand on the handlebars and signal a turn. (Practice these skills in a parking lot); Always look over your shoulder, and if possible, signal before changing lanes; Make sure that books, clothes, and other items are securely attached to the bicycle or carried in a backpack; and Use bells, horns, or your voice to alert pedestrians and bicyclists that you are approaching or passing.
- **Stay Focused: Stay Alert** - Never wear headphones; they hinder your ability to hear traffic. Always look for obstacles in your path (potholes, cracks, expansion joints, railroad tracks, wet leaves, drainage grates, or anything that could make you fall). Before going around any object, scan ahead and behind you for a gap in traffic, signal your intentions to move, and then follow through with your intentions. Be aware of the traffic around you. Ride defensively. Use extra care when riding in wet weather, ice, frost, or snow. Slow your speed and allow extra time and space to stop. Use extra care when crossing bridges which are extra slippery under wet conditions. Use caution when crossing a railroad track; cross tracks at a 90-degree angle and proceed slowly.

#### c. Wet weather riding

Whenever possible, you should avoid riding your bicycle in the rain. Riding a bicycle in the rain is like driving a car in the snow. You will not be able to stop as fast and must leave a larger distance between you and the obstacles around you. Your brakes will not work as efficiently when they are wet. You will not be able to turn as sharp without the danger of slipping. You must also ride away from or be cautious around painted lines, pot holes, sewer or drain grates, rail road crossings, bridges, wet leaves and any other area where a slippery surface can appear with water. Keep an eye out for puddles and turn your lights on if you have them. If you live in an environment where rain riding is expected, you should install front and rear fenders if you have not already done so. Use a cover for your bicycle if leaving it outdoors. Extensive rain can seep into the controller and battery and cause water damage.

#### d. Reflectors

The CPSC (US Consumer Product Safety Commission) requires front, rear, wheel and pedal reflectors. Your Outlaw includes federal regulated reflectors and they should not be removed. If needing to be replaced, replace them with authorized Prodeco reflectors or reflectors approved by the CPSC.

#### e. Night riding

Almost anywhere in the world today, bicycle night riding requires front and rear lights on your bicycle. You must install front and rear lights if you plan on riding at night. Check your local laws on what is required for night riding. Always wear retro-reflective clothing or material, not just white or florescent, especially on your ankles, wrists, back, and helmet. Only ride in areas familiar to you. Brightly lit streets are best. Always assume you are not seen by a driver. Children should NOT ride at night.

#### f. Adding accessories

When adding accessories to your bicycle you must check to confirm they do not lower the safety value of your bicycle. Prodeco Technologies offers authorized accessories for your bicycle which have been approved not to lower the safety value. Ask your authorized dealer or contact us if you are not sure about adding an accessory to your bicycle and the possibility of lowering your bicycle's overall safety.

### Chapter 5: Perfect Fit and Ride

It is very important your new Outlaw is adjusted properly for your size and for comfort. The Outlaw has multiple adjustments available to offer a comfortable and safe position for riding. A properly sized and adjusted bicycle allows the rider to remain fully alert and avoid injury. Review this chapter carefully and all the adjusting points of your new Outlaw. If you have difficulty in obtaining the most comfortable riding position or performing available adjustments, contact your authorized dealer for advice. You can contact Prodeco Technologies directly by phone or email and we will assist you with the proper adjustments for your bicycle and your size. The following list is the areas of adjustability the Outlaw offers:

- Saddle height
- Saddle nose angle
- Saddle distance to handlebar
- Handlebar height
- Fork height
- Brake lever angle
- Brake lever reach
- Fork suspension firmness

#### a. The basics

Understanding the basics of a bicycle frame size will help in determining the correct positions and adjustments for your body size and comfort. The Outlaw's frame was designed to easily accommodate all riders from 5' 8" to 6' 6" utilizing the available adjustments. The frame size can be considered anywhere from an 18" to 23" if comparing to traditional measurements. The most important information to remember when sizing your bicycle is that you are comfortable riding, especially when pedaling. With throttled electric bicycles some riders may choose not to pedal and the measurement will be different than for a rider who chooses to pedal and is the same size. Scooters for instance have a much lower saddle height than bicycles due to scooters not being pedaled. A higher saddle height is only recommended for riders who pedal allowing them a full extension of their leg per rotation of the crank.

#### b. Frame size

The Outlaw is considered an 18" MTB frame. The typical measurement number when choosing a correct frame size for a rider is the seat tube length. This number usually is between 17" to 19" for categorizing MTB bicycle measurements. The seat tube length is measured from the centerline of the crank (bottom bracket) to the top of the seat tube (seat tube clamp). There is another measurement sometimes forgotten which is actually more important and this is the top tube length (seat tube to the steering tube). Most manufacturers will proportionally adjust the top tube length according to the seat tube length and with stems being available in various lengths, fine tuning of this measurement is easily accomplished.

Prodeco Technologies Outlaw's frame measurement will differ from traditional bicycle frames due to the seat tube being longer than a traditional bicycle. The addition of the battery mount required an extension to the seat tube by 2 inches; therefore the measurement is 20". The measurement of the top tube and other frame components however follow the principals of an 18" MTB frame. The Outlaw's further has a high rake seat tube angle. With the high angle seat tube, as a tall rider raises their saddle to accommodate their longer legs, the saddle will pull back offering a longer distance to the steering tube.

#### c. Recommended sizing

In today's bicycle industry, the top tube length is actually more important than the seat tube length. With seat posts now available over 300mm, the seat tube length is no longer the most important number. The distance of the bottom bracket to the road should also be taken into consideration when sizing a bike. The top tube length is traditionally the distance from the center of the seat tube to the center of the steering tube. For purposes of sizing the Outlaw, we will name the distance of the center of the saddle to the center of the handlebar the steering length (similar to the top tube length).

You can adjust the steering length of your Outlaw by establishing the saddle position and seatpost height. The saddle position can be adjusted for height and distance from the steering tube via the quick release clamp and the saddle clamp. Keep in mind by increasing the height of the saddle, this will also increase the steering length due to the high rake angle of the seat tube. If you choose to use your bicycle as a scooter style vehicle only, you should establish saddle height at a lower position to reduce the center of gravity. Saddle height can be reduced to just above your inseam. Your inseam is the measurement of the inside of your leg.

#### d. Control position adjustments

The Outlaw includes a variable thumb throttle with an LED battery indicator on the right side and an 8 Speed twist shifter on the left side of the handlebar. The throttle can be adjusted on the handlebar to rotate further up or down, using the 3mm hex key included with your multi-piece tool kit. The shifter can be adjusted on the handlebar to rotate also using the multi-tool included with the bicycle. The brake lever assembly and throttle mount together and at a certain point of rotation, one will not rotate further without the other requiring to be rotated. If the factory settings on the throttle or shifter are uncomfortable for you or you cannot view the LED battery, you can loosen the throttle clamp and move it into a preferred position. As stated above, you may have to loosen the brake assemble to move the throttle to your desired position. Please see section e "Brake lever height adjustments" following this section to loosen and adjust the brake lever assembly and maintain correct brake lever height adjustments. To loosen and adjust the throttle, locate the 3mm hex bolt at the front underside of the LED battery indicator on the throttle. Use your 3mm hex key and insert it into the hex bolt and rotate a minimum of 3 times counter clockwise. The throttle will now be loose enough to move. **Throttle clamp bolts should be tightened to 25 lb\*in.**



#### e. Brake lever adjustments

The preferred level of the brake lever assemblies will vary from rider to rider. The brake lever assemblies can be rotated to a desired riding position. The optimal position can be found by extending your fingers straight while sitting in the saddle. Your fingers, when extended straight, should rest on top of the levers or slightly above the levers.

The brake lever assembly has a clamp bolt (see 1 in photo) accessible from the top of the bracket. Using the T-25 Torx ® wrench included within your multi-use tool, loosen the brake lever assembly by turning the T-25 bolt counter clockwise. The lever assembly will now be loose and you can rotate it up or down to establish the preferred position to apply the brakes. A brake lever assembly may require the throttle clamp or shifter clamp to be loosened to allow the brake lever assembly to rotate. The brake lever assembly, throttle and shifter mount can prevent each other not to rotate at a certain point; one will not rotate further without the other requiring to be rotated. A compromise may be required when attempting to align the brake levers and establishing the preferred throttle and /or shifter position. The optimum position to set your brake levers depends on your riding position but it should be the extension of your arm. Your brake lever should be located at the point where your fingers extend straight out from your arms. Upon finding preferred brake lever position, tighten the T-25 Torx ® bolt using your multi-use tool. **Brake lever clamp bolts should be tightened to 55 lb\*in.**

The reach can also be adjusted which determines the position of the lever in relation to the grip. The reach can be reduced or increased. It is important to note the decrease length of reach will result in reduced brake pad travel.

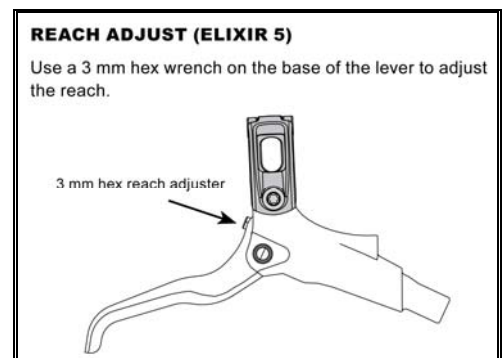
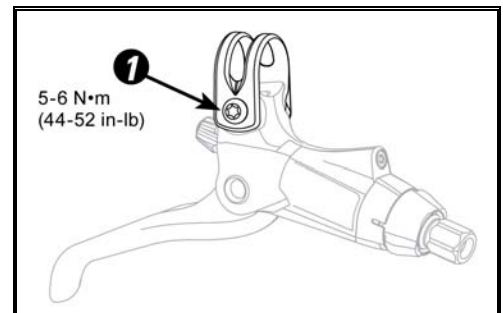



#### f. Suspension fork

The Outlaw uses a dual pre-load double crown adjustable suspension fork. The fork's dual leg adjustment offers either a softer or firmer ride for smoothing out the bumps in your path. The pre-load can be adjusted according to your weight and preference. You can easily adjust the suspension performance by rotating the knobs at the top of each leg at the crown.

The fork can also be adjusted for height in relation to the frame. Depending on riding style, the fork can be adjusted for an increased rake by adjusting the crown further up the stanchions. The higher crown adjustment would create a more upright riding position. For aggressive riding trail riding, the fork must have the crown adjusted to the lowest stanchion setting. The higher crown adjustment diminishes steering control and it is not recommended. The Outlaw ships with the crown in the lowest setting. (SEE PHOTOS)

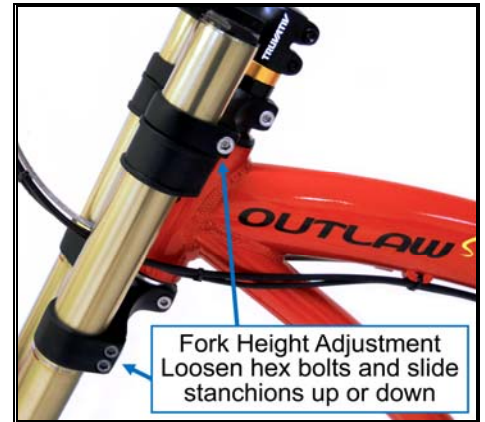

#### Chapter 6: Tire, Tube, Wheel and Axle Repair

The Outlaw was designed for ease of servicing. Repairs are no more difficult than on a traditional bicycle. Any neighborhood bicycle shop should be able to repair a flat, change a tire or replace a wheel. Please review the following chapter on how to remove and replace the front and rear wheel of your Outlaw.

##### a. Removing the rear motor wheel

The wheel incorporates a motor wire quick disconnect for removing the wheel. To remove the wheel following these instructions will only take a few minutes. Read the instructions fully before first attempting to remove the wheel.

- Prior to removing the wheel, shift the bicycle into gear 7 or 8 (the small COG/sprocket on the rear cassette. It will be easy to remove the wheel if the chain is at the end of the cassette. Make sure to spin the crank while shifting gears.
- Next, turn the battery ignition key to the "UNLOCK" position and remove the battery.
- To work on your bicycle, it may be easier to turn the bicycle upside down by placing blankets on the ground and resting the bicycle on the saddle and handlebar.
- Locate the motor disconnect weather proof plug on the left side of the bike frame 6 inches from the motor axle and separate the connector.
- Locate the cable tie which ties the motor wire to the frame. Cut the cable tie with snips.
- On each axle nut there is a rubber nut protector, remove these protectors simply by pulling on them. On the wired side of the axle, slide the rubber protector up the wire only a few inches.
- Using a wrench, turn counter clockwise each axle nut until the axle washers are loose.
- Remove the wheel from the frame by pulling on the wheel.
- The 8 speed freewheel mounted to the motor can be slid out away from the chain with no issue. The spring of derailleur may cause the lower pulley to get in the way of removing the wheel. Simply pull the pulley out of the way.



**CLOSED MOTOR CONNECTION**



**OPEN MOTOR CONNECTION**

##### b. Installing the rear motor wheel

The rear motorized wheel easily installs onto the rear frame dropouts within a few minutes. Follow the instructions below on installing the rear motor wheel. Additional cable ties are included with the Outlaw SS. One cable tie will be needed to install the motor. Read the instructions fully before attempting to install the wheel. (SEE PHOTOS)

- Pull or push the rear derailleur lower pulley with chain out of the way of the dropouts.
- Now check to make sure the chain is not in the way and align the wheel above (below if bike is not upside down) the dropouts and pay attention to the lining up of the disk brake rotor into the brake caliper (between the pads).
- Prior to inserting the wheel into the dropouts, pull the chain onto the cassette.



- Slide the motor into the frame dropouts by aligning the axle into the dropouts. The axle has flat edges which require the axle to enter the dropouts with the flat edges facing front and back. The axle with the motor wire protruding is to enter the left side dropout (the left side is when standing behind the handlebar).
- Now check to make sure the chain is not in the way and align the wheel above (below if bike is not upside down) the dropouts and pay attention to the lining up of the disk brake rotor into the brake caliper (between the pads).
- Each axle side has washers and a nut. Slide the washers over the axles and tighten nuts by hand.
- Using a wrench, fully tighten axle nuts. Axle nuts should be tightened to 250 lb\*in.
- Plug motor connection by aligning arrows on each end of the connector and slide together.
- Once connectors are plugged, you must test the connection. Install the battery as described in Chapter 8 "Battery Management" section c "Installing and locking the battery". Turn the ignition key to "ON" at the battery mount. LED lights on throttle will light up displaying power to the motor. Pull the rear motor wheel off the ground (if the bicycle is not turned upside down) and turn the throttle to test the motor. If the motor turns, the connection is solid. If motor does not turn, turn key to "OFF" position at battery mount and then check the motor connector to ensure a solid connection has been made. Test again after checking.
- After confirming a solid connection, use a new cable tie to connect the motor cable to the side of the frame and once tightened, cut off any excess amount.

c. Removing and installing the front wheel (20mm thru axle)

The front axle on your Prodeco Outlaw is a 20mm thick thru axle utilizing a sealed bearing hub. The sealed bearing hub slides over the axle. The axle requires to be slid out to remove the front hub. The axle is a smooth hollow aluminum pipe threaded at each end with a 6mm hex safety bolt. The axle is further held in place by the compression of the forks dropouts at the lower legs. The dropouts contain 2 bolts at the underside of each leg which upon tightening, lock the axle in place. Please follow these steps when removing the axle. To install the axle, simply reverse the steps. (SEE PHOTO)

- On the end of each axle there is a 6mm hex socket bolt. You will need to loosen one of the bolts from either side of the axle 50% for now.
- At the underside of each fork leg at the dropout, there are 2 hex bolts. The hex bolts compress the fork dropout to lock the axle in place. All 4 bolts (2 at each leg's dropout) are required to be loosened for the 20mm thru axle to be slid out.
- Once the 4 dropout bolts have been loosened, tap inwards on the safety bolt which has been extended 50%. This will cause the axle to start sliding thru the hub. After partially sliding the axle, completely remove the safety 6mm hex bolt and pull the axle out from the opposite side. The front wheel will then slide out.



d. Replacing a tube or tire

Read the previous sections to learn how to remove and replace the front and rear wheel. You will need to understand how to remove the wheel prior to replacing a tube or tire. This section only explains how to remove the tire from the rim and how to replace a tube.

Before explaining how to replace a tube and tire, details on the Outlaw's tubes and tires are discussed. Tubes and tires are 2 of the most important components on your new bicycle and must always be in optimum condition. It is important you understand about the tubes and tires equipped on your bicycle.

The Outlaw uses high-performance Continental Trail King tires with a 45 PSI rating. Bicycle tires are available in many designs and specifications, ranging from general-purpose designs to tires designed to perform best under very specific weather or terrain conditions. If, once you've gained experience with your new bicycle, you feel that a different tire might better suit your riding needs; your dealer can help you select the most appropriate design.

The size, pressure rating, and on some high-performance tires the specific recommended use, are marked on the sidewall of the tire. The most important part of this information for you is Tire Pressure. The best and safest way to inflate a bicycle tire to the correct pressure is with a bicycle pump that has a built-in pressure gauge.

**⚠ WARNING: Never inflate a tire beyond the maximum pressure marked on the tire's sidewall. Exceeding the recommended maximum pressure may blow the tire off the rim, which could cause damage to the bike and injury to the rider and bystanders.**

**⚠ WARNING: There is a safety risk in using gas station air hoses or other air compressors. They are not made for bicycle tires. They move a large volume of air very rapidly, and will raise the pressure in your tire very rapidly, which could cause the tube to explode.**

Tire pressure is given either as maximum pressure or as a pressure range. How a tire performs under different terrain or weather conditions depends largely on tire pressure. Inflating the tire to near its maximum recommended pressure gives the lowest rolling resistance; but also produces the harshest ride. High pressures work best on smooth, dry pavement. Very low pressures, at the bottom of the recommended pressure range, give the best performance on smooth, slick terrain such as hard-packed clay, and on deep, loose surfaces such as deep, dry sand. Tire pressure that is too low for your weight and the riding conditions can cause a puncture of the tube by allowing the tire to deform sufficiently to pinch the inner tube between the rim and the riding surface.

**⚠ CAUTION: Pencil type automotive tire gauges can be inaccurate and should not be relied upon for consistent, accurate pressure readings. Instead, use a high quality dial gauge.**

Ask your dealer to recommend the best tire pressure for the kind of riding you will most often do, and have the dealer inflate your tires to that pressure. Then, visually check inflation by sitting on the saddle with your weight and noticing your tires response. You should also squeeze tires and feel resistance so you'll know how correctly inflated tires should look and feel. Some tires may need to be brought up to pressure every week or two. Other high-performance tires may also have unidirectional treads, similar to the factory tires on your Outlaw: their tread pattern is designed to work better in one direction than in the other. The sidewall marking of a unidirectional tire will have an arrow showing the correct rotation direction. When replacing your tires with tires that are unidirectional, be sure that they are mounted to rotate in the correct direction.

There are primarily two kinds of bicycle tube valves: The Schrader Valve and the Presta Valve. The bicycle pump you use must have the fitting appropriate to the valve stems on your bicycle. The Outlaw uses Schrader valves. The Schrader valve is like the valve on a car tire. To inflate a Schrader valve tube, remove the valve cap and clamp the pump fitting onto the end of the valve stem. To let air out of a Schrader valve, depress the pin in the end of the valve stem with the end of a key or other appropriate object. The Presta valve has a narrower diameter and is only found on bicycle tires. To inflate a Presta valve tube using a Presta headed bicycle pump, remove the valve cap; unscrew (counterclockwise) the valve stem lock nut; and push down on the valve stem to free it up. Then push the pump head on to the valve head, and inflate. To inflate a Presta valve with a Schrader pump fitting, you'll need a Presta adapter (available at your bike shop) which screws on to the valve stem once you've freed up the valve. The adapter fits into the Schrader pump fitting. Close the valve after inflation. To let air out of a Presta valve, open up the valve stem lock nut and depress the valve stem.

**⚠ WARNING: Patching a tube is an emergency repair. If you do not apply the patch correctly, the tube can possibly fail, which could cause you to lose control and fall. Replace a patched tube as soon as possible.**

To remove a tire or tube, follow these instructions (you will need tire levers or a similar tool to hold open the bead of the tire):

- Let all the air out from the tube of the wheel having the replacement.
- Remove the wheel as described in detail in the previous sections.
- Remove the inner tubes air valve cover.
- Pull back the tire bead away from the rim. You will see the tube and the inside of the tire. If it requires too high pressure to pull back the tire bead, there may be still air in the tube. Check to confirm all the air is out of the tube.
- Using 2 tire levers or similar tools, insert one lever end in between the tire bead and the rim but make sure the lever is on top of the tube and you are not pinching the tube.
- Slide the second lever about 4-6 inches to the side of the first lever. Be sure not to pinch the tube and to confirm you have the lever on top of the tube and not under the tube. Slide the lever down the side of the wheel between the tire bead and rim edge while lifting the tire bead and sidewall over the rim edge.
- If removing only the tube, you can now pull the tube outside the side of the tire wall. If replacing the tube, you can now install the new tube.
- If removing the tire, use the tire levers and repeat the previous steps and remove the opposite side of the tire's sidewall bead on the same side of the rim you removed the first tire bead. The tire may easily come off the rim if you pull the tire bead over the edge of the rim and the tire levers may not have to be used.

To install a new tire, follow these instructions:

- When installing a new tire you should first insert the tube into the tire. The tube should have been partially inflated to a soft but full feel removing any wrinkles in the tube.
- Check the mounting side of the rim and confirm the directional path of the tire. High performance tires are usually directional tires and the arrow on the sidewall represents the rotation of the tire.
- Place the valve of the tube into the valve hole of the rim and slide the bead of the tire over the edge of the rim.
- Push the one side wall and bead of the tire around the edge of the wheel's rim. The tire will slide into place and may become tight as you finish.
- Once one side of the tire is inserted in the rim, check to make sure the valve stem lines up properly and the tube is smooth across the rim and inside of tire. The tube should not be bunched up in any area.
- Where the tube valve is, slide the second wall and bead of the tire into the edge of tire rim. Follow pushing the tire wall and bead into the inside edge of the rim.
- You will get to an area of only a few inches left and you will need to apply pressure to push the tire side wall and bead behind the edge of the rim.
- Once the tire is fully inserted, check for any areas on both sides if the tube is exposed. The tube must not get trapped between the tire bead and rim edge.
- Locate the tube valve and use your hand to push on the tire on the outside of the valve to help push the valve further out through the rim.
- Fill the tube with 50% air and then check the tire bead and rim edge again to see if the tube is protruding anywhere. Once you confirm the tube is not protruding, you can fill the tire to your desired air pressure.
- You are now ready to install the wheel back onto the bicycle according to the previous sections.

## Chapter 7: Maintenance and Replacement

Your new Outlaw was designed for ease of use and owner servicing. There are no tasks which require advanced skills. Most maintenance and replacing of parts were designed to be accomplished by the typical bicycle rider. Please read this section to learn how to keep your Outlaw performing like new.

### a. Keeping your bike clean

Your new Outlaw is an outdoor friendly electric bicycle but should be kept clean and free from dirt. Dirt on and around seals and drive train components can cause premature wear and dirt on paint and part finishes can cause premature aging. If storing your bicycle outdoors under the elements, you must keep it covered with a high quality bicycle cover to avoid rain, snow or dirt damaging your new bicycle.

To clean your bicycle, follow these instructions:

- Your bicycle incorporates electrical components; it is advised when washing your bicycle you should first cover the throttle and battery base. Use a plastic bag or a piece of plastic wrap to cover the components. Place the bag or wrap around the complete throttle assembly and use a rubber band or tape to secure. The battery should be removed prior to cleaning and a plastic bag or wrap secured by tape can be used to cover the battery base. If you are planning for a ride after washing, it is recommended the saddle also be covered. The saddle has miniature holes where there is stitching and water can seep into these small holes.
- To wash your bicycle you will need a small bucket of warm water with car soap, sponge, small brush, chain lube and a few rags or towels.
- Rinse your bicycle off with a light spray of water to remove any dirt on the surface. Using the sponge and warm soapy water, wash the frame and frame components which include the forks, handlebar and seat post. Start from the top of the bicycle working your way down.
- Once the frame is washed, use the sponge to clean the motor, spokes, chain guard and rims.
- The tires, pedals, crankset and chain will be the remaining items needing to be washed. Use the brush first on the tires and then the pedals. Rinse the brush and then using the warm soapy water, clean the chain ring, freewheel and finally the chain. If the chain and drive train are very dirty or greasy, a bicycle degreaser should be utilized.
- After washing, spray the bicycle down with fresh water.
- Use the rags or towels to dry off the bicycle. Start by drying the frame first, followed by the components, the wheels, tires and then the drive train.
- Once the drive train is dry, use a chain lube to lubricate the chain.

b. Avoid scratching your bike

Your new Outlaw is a high quality bicycle has been designed to withstand the elements by utilizing stainless steel, anodized and painted aluminum alloys, brass plus galvanized or painted metals. Stainless steel and brass are used in their natural forms and can withstand the elements with no additional protection required. The majority of your bicycle however is fabricated from aluminum alloys which have either a painted finish or have been anodized. Aluminum does not rust but can discolor and corrode over time. The frame has a 3 layer paint finish which protects the aluminum and graphics. Components such as the handlebars, crank arms, chain guard, seat post and more have been anodized through an electrolytic process which increases corrosion and wear resistance. If the frame or components become scratched, these items could slightly corrode around the scratched area. Depending on the care of your bicycle, a scratch could take month or years for corrosion to appear. To maintain future value and years of beauty, it is best to be careful when folding and moving your bicycle not to scratch the metal surfaces. If a surface is scratched, use clear nail polish or black nail polish to cover and seal the scratch.

c. Brake bed-in process and information

Both brakes on your Outlaw are high performance Avid Elixir 5 Hydraulic Disc Brakes. No adjusting is required as hydraulic brakes self-adjust. They have powerful stopping power but must be bed in for maximum performance. Please review the following guideline and you can also refer to the included Avid Elixir 5 brake guide included with your starter kit. If you are unsure as to a component or installation procedure, please contact your local authorized dealer or Prodeco Technologies.

### **AVID SAFETY INFORMATION**

Brakes are a safety-critical item on a bicycle. Improper setup or use of brakes can result in loss of control or an accident, which could lead to a severe injury.

Avid brakes are a performance product that offers increased stopping power over brakes that you may be used to. This greater power requires less effort to lock-up a wheel when braking. A wheel lock up might cause you to lose control and possibly cause injury.

It's your responsibility to learn and understand proper braking techniques. Consult the owner's manual for your bicycle and a professional bike dealer.

### **ALWAYS RIDE UNDER CONTROL**

Remember, it takes longer to stop in wet conditions. To reduce the possibility of an accident and minimize trail erosion, you should avoid locking-up your wheels.

### **FOLLOW THESE INSTRUCTIONS CAREFULLY**

If you do not understand the instructions, have the brakes serviced by a professional bicycle mechanic.

**Disc brakes are OIL SENSITIVE!** Do not spray any solvents or lubricants in the vicinity of the rotors or brake pads. NEVER touch the pad surface or rotor surface with your fingers. Doing so will significantly degrade braking performance.

### **AVID WARNING**

Do not touch the braking surface of any rotor with your bare hands, because the oils from your fingers will degrade its performance. Always wear gloves, or handle the rotor by its spokes. Disc brakes become very hot during use. Do not touch the caliper or rotor immediately after use. Make sure the brake has cooled down before making any adjustments.

### **Hydraulic brake information**

- Use only DOT 4 or DOT 5.1 fluids with Avid brakes. DOT 5.1 fluids provide enhanced braking performance.
- Do not use a fluid other than DOT fluids suggested. Doing so will damage the system make the brakes unsafe to use.
- DOT fluids will damage painted surfaces. If any fluid comes in contact with a painted surface (i.e. your frame), wipe it off immediately and clean with isopropyl.
- Do not allow any brake fluid to come in contact with the brake rotors. If this occurs, clean the rotors with isopropyl alcohol.
- Do not allow any brake fluid to come in contact with the brakes pads. If this occurs, the pads are contaminated and must be replaced.
- Used DOT fluid should be recycled or disposed of in accordance to local and federal regulations.
- NEVER pour used DOT fluid down a sewage or drainage system or into the ground or a body of water.



## DISC BRAKE PAD AND ROTOR BED-IN PROCEDURE

All new brake pads and rotors should be put through a wear-in process called 'bed-in'. The bed-in procedure, which should be performed prior to your first ride, ensures the most consistent and powerful braking feel along with the quietest braking in most riding conditions. The bed-in process heats up the brake pads and rotors which deposits an even layer of brake pad material (transfer layer) to the braking surface of the rotor. It is this transfer layer that optimizes braking performance.

### **⚠ WARNING:**

The bed-in process requires you to perform heavy braking. You must be familiar with the power and operation of disc brakes. Braking heavily when not familiar with the power and operation of disc brakes could cause you to lose control of your bicycle, which could lead to a crash and could lead to serious injury and/or death. If you are unfamiliar with the power and operation of disc brakes, you should have the bed-in process performed by a qualified bicycle mechanic.

### **👉 IMPORTANT:**

To safely achieve optimal results, remain seated on the bike during the entire bed-in procedure.

- 1** Accelerate the bike to a moderate speed, then firmly apply the brakes until you are at walking speed. Repeat approximately twenty times.
- 2** Accelerate the bike to a faster speed. Then very firmly apply the brakes until you are at walking speed. Repeat approximately ten times.

### **👉 IMPORTANT:**

Do not lock up the wheels at any point during the bed-in procedure.

- 3** Allow the brakes to cool prior to any additional riding.

### **Before each ride**

Check houses for signs of wear. Squeeze the brake lever firmly and check for proper brake function. Check pads for wear and replace if necessary. Ensure rotors are free of foreign substances and oils.

### **Pad Break In and Noise**

It may take anywhere from 20 to 40 complete stops to break in Avid pads. You may begin to notice an increase in braking power after the first ride. Brake noise can occur not only during the break-in period but off and on throughout the life of the brake pads. Noise is dependent upon factors such as brake setup, rider weight, riding style, braking style, and riding conditions (i.e. dust, soil, and contamination of friction surfaces).

### **Care and Cleaning**

Extreme care must be taken when cleaning both the bicycle and its new disc brakes. Under normal use, it is not necessary to clean the caliper rotor or pads. If necessary, use only water and dish detergent to wash the caliper and rotor being sure to thoroughly rinse all soap residues from the rotor. Dry with a clean paper towel.

#### d. Pad Replacement

A pad should be replaced when its total thickness (backing plate and friction material) is less than 3mm.

## DISC BRAKE PAD INSTALLATION INSTRUCTIONS

- 1** Remove pad retainer bolt.  
Start by removing the e-clip on the wheel side of the caliper, then unscrew the retainer bolt using a 2.5 mm hex. Remove the retainer bolt all the way.
- 2** Push the pistons back in.  
Elixir calipers are self-adjusting, the pistons need to be pushed back into the body to their original position before the new pads can be installed. The safest way to do this is with the old pads still in the caliper to protect the pistons. Place a flat-blade screwdriver between the old pads, then carefully rock it back and forth, pushing the pistons back into their bores.
- 3** Remove the old pads.  
Grab the pad tabs and pull straight out.
- 4** Install the new pads and spreader.  
Be sure the spreader clip is oriented to the pads as shown. Align the hole in the spreader clip with the holes in the pad tabs. Squeeze the pad and clip assembly together, then insert into the caliper as a unit. Firmly push until the assembly is seated into place.
- 5** Re-install the pad retainer bolt.  
Replace the pad retainer bolt, tighten to torque specifications, and replace the e-clip on the wheel side of the caliper.

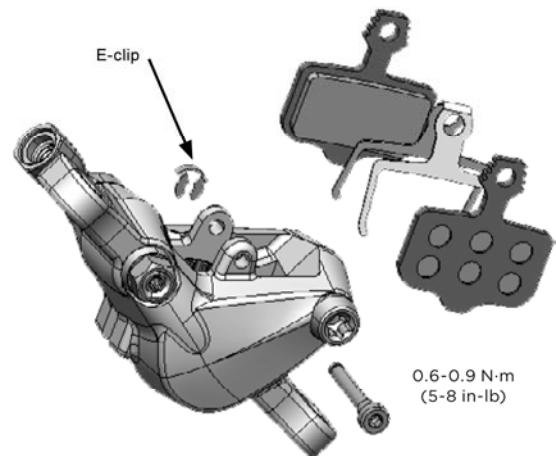



e. Derailleur adjustment (SRAM X9)

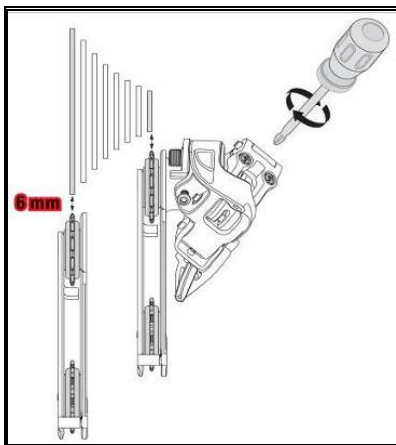
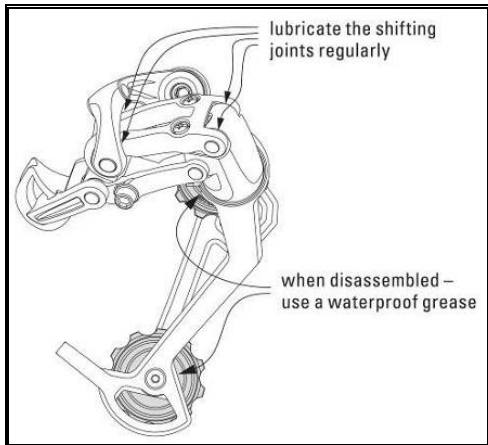
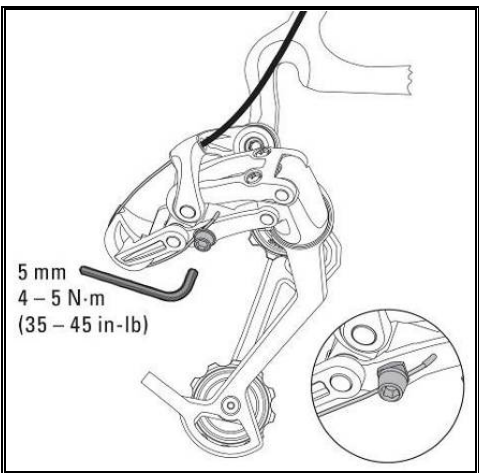
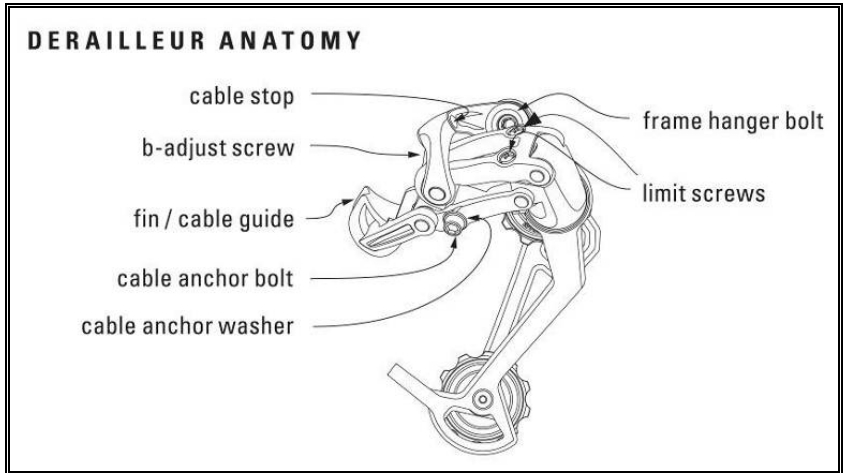

**LIMIT SCREWS ADJUSTMENT**

- View the rear derailleur and pulleys from behind the rear of the bicycle.
- Turn the limit screw marked 'H' on the outer link of the derailleur to align the upper guide pulley center with the outboard edge of the smallest cog – clockwise moves the guide pulley inboard towards the wheel.
- While turning the crank, push the rear derailleur towards the larger cogs by hand.
- Align the upper guide pulley under the largest cog, center to center, by turning the limit screw marked 'L' on the outer link – clockwise moves the guide pulley outboard away from the spokes.

If the chain of your bicycle falls off at the largest COG/sprocket or the chain is having problems remaining on the correct gear, you may need to adjust your derailleur. There are a multiple ways to adjust your derailleur but for a simple adjustment on the changing of gears, follow these instructions.

- Located at the shifter, the adjusting knob where the cable enters the shifter will adjust gear shifting. This knob allows the loosening or tightening of the cable. Rotate this knob clockwise or counterclockwise until the derailleur is properly changing gears. This is a quick fix but for a correct adjustment, the permanent adjustment should be at the derailleur cable locking plate and fixing bolt with the shifter knob used for fine tuning.



**SHIFTING ADJUSTMENT**

Check that the chain and the rear derailleur are in the smallest cog position. While pedaling, twist the shifter up one detent. If the chain hesitates or does not shift to the second cog, increase the cable tension by turning the shifting adjustment knob counterclockwise. If the chain shifts beyond the second cog, decrease the cable tension by turning the shifting adjustment knob clockwise. Repeat the two former steps until shifting and cable tension is accurate. While turning the crank, shift the chain up and down the cassette several times to ensure your derailleur is shifting smoothly.



For a more detailed adjustment of the derailleur, you should bring your bicycle to an authorized Prodeco dealer or a neighborhood bike shop who services SRAM derailleur. There is also a SRAM derailleur guide included with your bike.

## Derailleur Troubleshooting

Problem	Cause	Remedy
Chain jumps from smallest sprocket to frame dropout.	High gear limit screw is not adjusted properly.	Turn in "screw H" until the guide pullet is aligned with the smallest sprocket.
Difficult or impossible to shift chain onto smallest sprocket.	High gear limit screw is not adjusted properly.	Unscrew "screw H" until the guide pullet is aligned with the smallest sprocket.
Chain jumps over largest sprocket and falls between the spokes and largest sprockets or inner cage plate scrapes on spokes.	Low gear limit screw is not adjusted properly.	Turn in "screw L" until the guide pullet is aligned with the largestest sprocket.
	Rear derailleur or derailleur hanger is bent.	Straighten or replace.
Delayed shifting.	Clearance between guide pulley / sprocket is too large.	Adjust 'b-adjust screw" by rotating counterclockwise.
Rough shifting behavior.	Clearance between guide pulley / sprocket is too small.	Adjust 'b-adjust screw" by rotating clockwise.
Shifts more gears onto smaller sprockets than intended.	Shift cable insufficiently tensioned.	Turn barrel adjuster on the shifter counterclockwise.
Delayed shifting onto larger sprocket.	Shift cable insufficiently tensioned.	Turn barrel adjuster on the shifter counterclockwise.
Delayed shifting onto smaller sprocket.	Shift cable is too tight.	Turn barrel adjuster on the shifter clockwise.
	Excessive cable friction, pinch or poorly routed cable.	Lubricate or replace cable & housing. Check for excessive bending of cable housing.

### f. Wheel check

From time to time you should check the truing of your wheel and the condition of your spokes. Your spokes can become loose over a period of time, especially if your wheel needs truing. The easiest way to check the truing of your wheels is as follows:

- Make sure the battery is turned off and the key is out of the ignition.
- It is best to turn the bicycle upside down and place it on a blanket to avoid scratching the handlebar controls or saddle. When turning the bicycle upside down, rest the bicycle on the handlebar and saddle. If you prefer not turning the bicycle upside down you will need to pick up the wheel off the ground to test.
- Pick up the front of the bicycle by the handlebar and spin the wheel, the wheel should spin straight. If the wheel wobbles from side to side more than 1/8", the wheel should be trued. Truing is required to be performed by a person familiar with truing. Bring your bicycle to your local bicycle shop to true the wheel. To check the rear wheel, pick up the back of the bicycle by the frame and repeat the step above.
- To check for spoke tension, this can be done by squeezing 2 parallel spokes together. The spokes should be tight and you should not be able to bend the spokes. If the spokes bend and feel loose, it is important to bring the bicycle to your local bicycle shop and ask for them to tighten the spokes and true the wheel.

**⚠ WARNING:** *When placing your hands near the wheels of your bicycle, you must confirm the key has been removed from the battery and the battery is removed from the bicycle. If the motor powers while your hands are near the wheels, you could become seriously injured.*

### g. Lubricating

A common area of maintenance with all bicycles is lubrication. Your Outlaw was designed to be virtually maintenance free but depending on the amount of riding and the environment, your bicycle should be lubricated from time to time. Areas not requiring lubrication are the HUBs, Bottom Brackets and Headset. They have bearing systems which do not require lubrication and any maintenance on these areas should be performed by a service agent.

Lubricating is always at the point where 2 surfaces touch together and friction is created. Your local neighborhood bicycle shop or most mass merchants who sell bicycles will offer various types of lubes for your bicycle. Below are the areas you should lubricate according to your maintenance schedule at the end of this chapter.

- **Chain:** The chain should be lubricated at each of the links. You can turn the crank counter clockwise while lubricating each area of pivot.
- **Forks:** Your forks are suspension forks and you should use a lubricant which does not dissolve rubber seals. Place a few drops where the fork stanchions (top legs) enter the seals of the lower legs.
- **Brakes:** Where the brake arms pivot will require a drop of lubricant. Do not put lubricant on the brake rotors or pads. The brake levers pivot pins require a drop of lube at the top of the pin.

Any other type of lubrication or greasing of bearings should be performed by an authorized Prodeco Technologies dealer.

### h. Crankset

The crankset of your Outlaw is a multi-piece system which includes a bottom bracket, crank arms, chainring, chainring bolts, chain guard and chain. All items are designed as maintenance free components except for lubricating the chain from time to time. The bottom bracket is a sealed bearing system with no serviceable parts. Each component of the crankset has an industry standard measurement and is available through your dealer or through Prodeco Technologies directly. Traditional bicycle components will also fit into these measurements. Please refer to the Chapter 12 Parts and Components list for replacement part numbers and the part measurements.

### i. Headset

The headset is a sealed bearing system with CNC'd aluminum alloy cups. The system is designed to offer years of issue-free performance. These are maintenance free systems and should not be serviced by anyone other than a knowledgeable bicycle repair shop. The headset is what holds the fork steerer tube tight to the frame. If you notice the handlebar is loose to the fork, bring your bicycle to a local bicycle shop so they can readjust the stem and tighten the headset.

j. Maintenance schedule: As a common practice you should follow your maintenance schedule. You should study it and allow it to become second nature to your riding.

Maintenance Schedule	Each Ride	Weekly	Monthly	6 Months	Yearly
Tire Pressure	X				
Tire Condition	X				
Visual Inspection	X				
Brake Lever Pressure	X				
Quick Releases	X				
Handlebar Alignment	X				
Saddle Alignment	X				
Battery Pack Locked	X				
Wheel Check	X				
Inspect Frame Condition (include welds for fissures)		X			
Clean and Lubricate Chain		X			
Check Brake Pads		X			
Lubricate Forks			X		
Lubricate Brakes & Cables			X		
Lubricate Folding Mechanism			X		
Check All Bolts and Torque Settings			X		
Clean Bicycle			X		
Charge Battery			X		
Check Wheel Spokes			X		
Inspect Rim Condition			X		
Inspect Saddle, Rails and Clamp			X		
Grease Pedal Bearings				X	
Check HUB Bearings				X	
Check Headset Bearings				X	
Check Bottom Bracket Bearings				X	
Replace Brake Pads					X
Replace Brake Cables (depends on use)					X
Replace Tires (depends on use)					X

k. Torque specifications for common parts: Nuts and bolts for your bicycle are set to standard torque settings at the factory. Over time of use and shipping, settings may change and nut or bolt could become loose. Below is a chart on the torque settings in Lb per Inch for the common parts of the Outlaw. They have also been converted to Lb per Foot and NM.

Torque Item	lb per In	lb per Ft	N M
Axle nut (front motor)	250 lb*in	20.8 lb*ft	28.25
Bottom bracket	420 lb*in	35 lb*ft	47.46
Brake lever clamps (at handlebar)	55 lb*in	4.6 lb*ft	6.21
Cassette/Freewheel	300 lb*in	25 lb*ft	33.9
Chainring bolts	80 lb*in	6.7 lb*ft	9.04
Crank bolt	350 lb*in	29.2 lb*ft	39.54
Crank bolt cap (if applicable)	100 lb*in	8.3 lb*ft	11.3
Derailleur bolt	80 lb*in	6.7 lb*ft	9.04
Disc brake caliper bolts (at frame)	80 lb*in	6.7 lb*ft	9.04
Disc rotor bolts	55 lb*in	4.6 lb*ft	6.21
Disc Brake Cable Arms (pinch bolt)	55 lb*in	4.6 lb*ft	6.21
Headset locknut	150 lb*in	12.5 lb*ft	16.95
Kickstand bolt	100 lb*in	8.3 lb*ft	11.3
Pedals	300 lb*in	25 lb*ft	33.9
Saddle rail clamp bolts (M6)	140 lb*in	11.7 lb*ft	15.82
Shifter (at handlebar)	20 lb*in	1.7 lb*ft	2.26
Stem adjustable bolts	150 lb*in	12.5 lb*ft	16.95
Stem clamp binder bolts (4 bolts)	60 lb*in	5 lb*ft	6.78
Stem quill bolt	250 lb*in	20.8 lb*ft	28.25
Throttle	25 lb*in	2.1 lb*ft	2.825
V brake bolts (at frame)	80 lb*in	6.7 lb*ft	9.04
Quick Release (at half way tighten the lever with resistance)			

## Chapter 8: Battery Management

This section describes your battery and similar to Chapter 3, section o. "Charging your battery" but goes into further detail.

### a. About your battery

The Li-ion battery system of the Outlaw is the latest technology with a LiFePO<sub>4</sub> chemistry. This battery is maintenance free with no serviceable parts. You must never open the battery as this will void the warranty. Each battery has a specific serial number and barcode which can be found on the underside of the battery. Please read the warning labels on your battery.

### b. Removing the battery

The Outlaw battery removes easily for charging or storing. The battery base utilizes an ignition key to lock the battery in place and to avoid theft. The battery will not power the bicycle unless locked in place. There are 3 points on the ignition for the key. There is the "UNLOCK" position which allows the battery to be removed and the key can slide in and out. There is the "OFF" position which locks the battery in place, the key can be slid out but the bicycle is not powered. The last position is the "ON" position. The bicycle is now powered ON, the battery is locked and the key is in and cannot slide out.

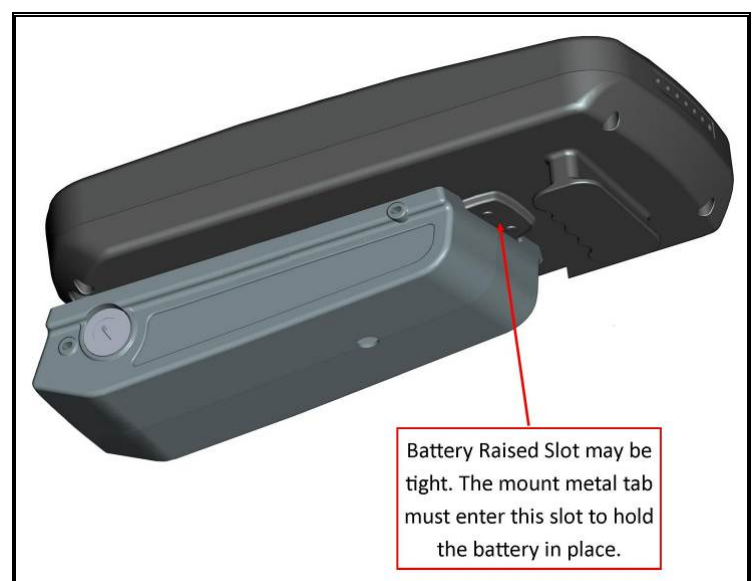
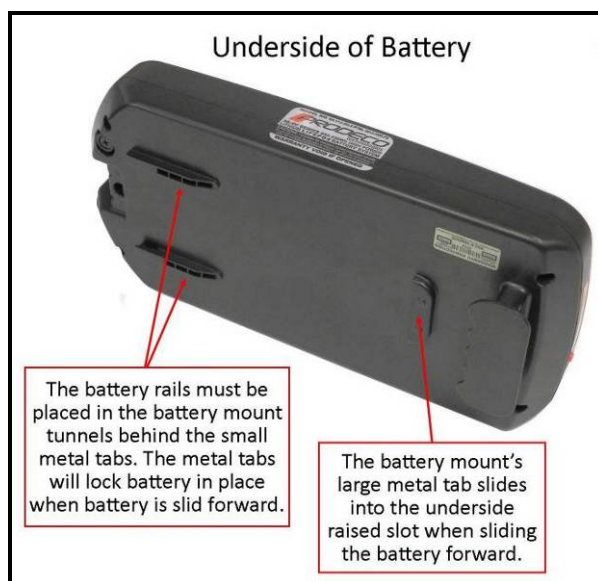
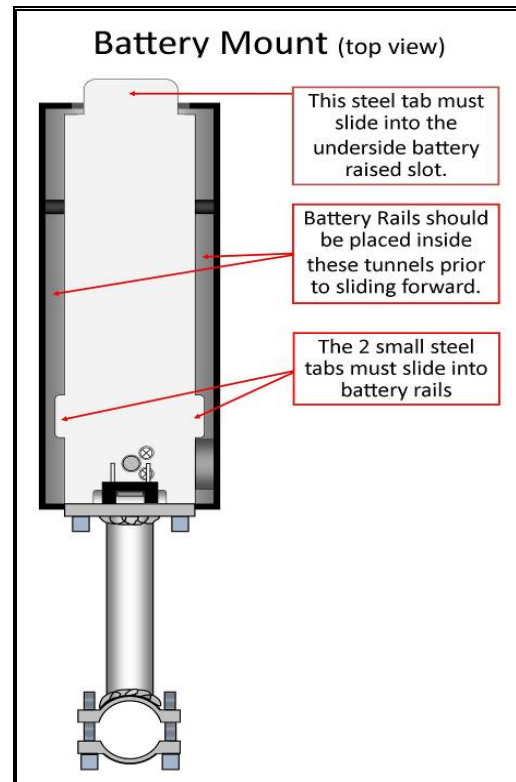
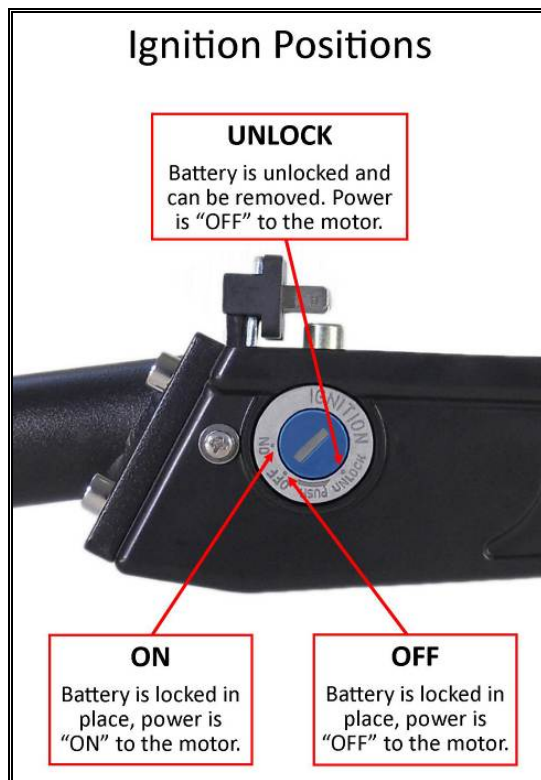





#### c. Installing and locking the battery

- As shown in the photos above, the battery has 2 thin “slotted rails” (1 on each side of the battery towards the front) and a “raised slot” (towards the rear and near the handle) at the underside of the battery. These rails and slots hold the battery in place when riding.
- The battery mount attached to the bicycle has one large metal tab at the rear and 2 small metal tabs at each side.
- When laying the battery onto the mount, place the battery so the rear “raised slot” near the battery handle is behind the large metal tab on the mount. The 2 “slotted rails” on the underside of the battery should be behind the 2 small metal tabs on the mount. The battery will now be resting flat on the mount.
- Firmly slide the battery forward allowing the ends of the underside rails to fasten over the 2 small tabs (2 small tabs lock into the “slotted rails”). The mount’s large metal tab at the rear must also enter the “raised slot” of the battery underside. The metal tabs will firmly hold the battery in place.
- You may have to use some force when installing the battery for the first time. Once installed for the first time, it is not as difficult to install afterwards.
- Upon the battery being fully slid into place, the key will then lock the battery in place and the LED lights of the throttle will light once the key is turned into the “ON” position. If the key has difficulty locking the battery, attempt to slide the battery in place again, following the instructions above.

#### To remove the battery, follow these instructions:

- Locate the key ignition on the battery base and turn the key in a counter clockwise rotation to the “UNLOCK” position. You must push the key in to turn from the “OFF” position to the “UNLOCK” position.
- Grab the handle at the back of battery and pull towards the back of the bicycle to slide it off.
- The battery is now transportable and can be charged away from the bicycle.

#### d. Charging the battery

The battery can be charged on or off the bicycle. If charging the battery on the bicycle, the key should be in the “OFF” position.

To charge the battery, follow these instructions:

- Remove the rubber cover off the battery’s RCA charging input.
- Insert the charging plug from the charger into the battery’s RCA charging input.
- Insert the charger’s power cord into a wall outlet.
- The charger’s LED light will light RED while the charger is charging the battery.
- The charger’s LED light will light GREEN upon the battery being fully charged.
- The top of the battery includes a battery indicator to also check for a full charge. Press the indicator button to display the battery’s energy storage.
- Once the battery is charged, you should discontinue charging and remove the charger.
- Unplug the charger’s power cord from the wall and remove the charging plug from the battery.
- Lastly, cover the RCA charging input with the attached rubber cover and you are ready to install the battery pack back onto your bicycle.

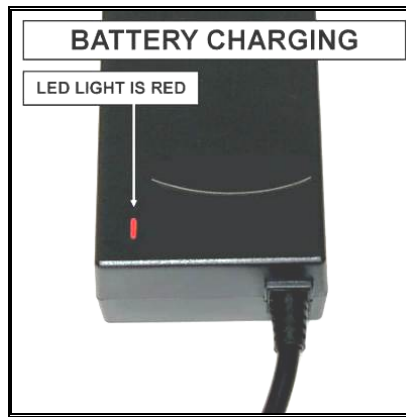

#### e. Storing the battery

The Li-ion battery the Outlaw utilizes is the safest and latest technology in Li-ion battery cells. It is recommended that you do not store the battery in extremely hot conditions. If the bicycle is being stored indoors in a cool environment, the battery should be stored on the bicycle in the “OFF” position. The battery should be kept away from fires or sparks and also away from possible water damage.

#### f. Battery power indicator

The Outlaw has a 3 LED light indicator on the handlebar throttle displaying the battery power available. There is also a 3 LED light display battery indicator on the battery itself. The LED indicator on the throttle is explained in Chapter 9: Electrical Components, section d. “Throttle”. The indicator on the battery is explained below. The battery indicator has 3 LEDs displaying 3 levels of power. When pressing the indicator button, the lights will light according to power storage. When pressing the button, if the 3 LEDs light up, the battery is at over 50% power to full. If only 2 LEDs light up, the battery is at 50% power or possibly less and should be charged. If only 1 LED lights up, the battery is near depletion and should be recharged immediately.

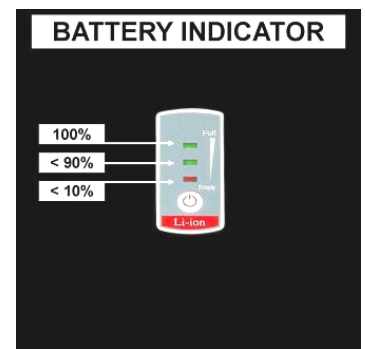

#### g. Battery replacement

If your battery is no longer working properly and needs replacing, you can contact your local authorized dealer for a replacement or contact Prodeco Technologies directly. Contact [service@prodecotech.com](mailto:service@prodecotech.com) or call 800-943-6190 to discuss the issue and determine if it is the battery. It is very rare for a LiFePO4 battery to have issues in the first 2 years and there may be another situation with the bicycle rather than the battery, if the bicycle is not powering properly. The battery is covered under warranty for the first 2 years of use. After 2 years, a replacement battery can be purchased by contacting your dealer or Prodeco Technologies. The battery part number and price can be found in Chapter 12.

#### h. Battery disposal

The LiFePO4 battery that comes with your Outlaw is a non-hazardous battery. We do however suggest recycling the battery and disposing of it by the following means:

- Return the battery to your local authorized Prodeco Technologies dealer.
- Return the battery directly to Prodeco Technologies.
- Dispose of the battery at your local city recycling facility.

## Chapter 9: Electrical Components

The Outlaw electric components were developed to be maintenance free with no serviceable parts. There are 5 components used to power your bicycle. Each component can easily be replaced by the average person with minimal mechanical skills. The design has been simplified so your local bicycle shop can service it without issue and minimal time. Please review the sections below on the electrical components used on your Prodeco bicycle and how to replace a component for a new one. Each electrical component is listed, except for the battery which was detailed in Chapter 8. Each individual component part number can be found in Chapter 12.

#### a. HUB motor

The HUB motor utilized on your Outlaw is one of the most advanced e-bike HUB motors developed today. It is a high efficiency, high torque brushless direct drive motor with a simplified design utilizing sealed bearings and no gears. The rear dropouts incorporate Prodeco’s uniquely designed stainless steel axle plates which have been specifically engineered to spread the torque of the motor through the dropout and rear stays. The stainless steel plates further act as safety devices strengthening the rear aluminum dropouts. When installing the motor, you must always install the axle plates.

The motor offers a nominal 750W of power at 48 Volts and a peak of 1200W. The power is sufficient to move the bicycle and rider on flat surfaces at speeds up to twice what a typical rider pedals. Steep inclines may require pedaling by the rider to power over the incline. It is highly suggested the rider pedals along with the motor to enhance traveling distance even on flat surfaces. The motor is powered through a "Hall Effect Sensor" approach. A "Hall Effect Sensor" motor is powered in 3 stator phases. As power is phased, the motor advances forward. The axle of the motor is the spindle of the stator. The stator remains fixed while the fully lined Neodymium magnet hub floats over the stator.

A weatherproof connector at the motor connects the wiring harness to the motor. This connector is an 8 pin brass connector and designed to withstand the elements. If the motor needs to be replaced, the connector simply has to be unplugged for the motor to be removed as explained in Chapter 6, section b. When installing the motor, it is very important the connector is plugged properly or the motor will not power. There are 2 arrows, one on each end of the connector which must align. There is an additional line on the inside connector which must meet the edge of the outside connector when inserting for the motor to have a solid connection.

The motor is covered under warranty as a complete wheel including spokes and rim to the consumer. If the motor fails, contact Prodeco Technologies or the closest Authorized service center for a replacement. Simply remove the motor as explained in Chapter 6. The motor can also be purchased separately. Refer to Chapter 12 for the part number and price.

#### b. Brushless hall sensor controller

The motor on the Outlaw requires a specific controller to properly produce the right "Hall Sensor Effect" as described in the previous section regarding the motor. The controller that comes with your bicycle has been designed to be easily changed if an issue was to occur. The controller is considered the brains of the bicycle and is located in the battery base which is attached to the bicycle. The battery base is the box where the key inserts for the ignition. The bolts holding the cover to the base can easily be removed within a few minutes. Once the cover is off of the battery base, the controller can be disconnected. If removing the controller, you must first remove the battery completely from the bicycle. There is only one way to connect and disconnect the controller from the bicycle. No two connections are the same.

#### c. Wiring harness

Your bicycle uses a separate wiring harness for the motor to plug to the controller. This allows for easy replacement.

#### d. Throttle (SEE PHOTO)

The variable throttle included with all Prodeco bicycles has an On/Off button. The red button below the battery indicator on the throttle engages the power to the motor. The thumb throttle was designed to allow you the ability to choose the riding speed and determine the amount of torque off the line. Similar to an automobile, the throttle mimics the depressing of the accelerator. The higher the speed, the less distance per charge (less distance per gas tank), the faster you accelerate off the line, the less distance per charge. If there are multiple stop and starts, this will also affect the range of distance per charge. It is recommended you become accustomed to your riding style and adjust the style depending on distance needed per charge. For example: if you are planning a short local trip, full throttle at takeoff and top speed will not be an issue due to your ability to be able to recharge the battery prior to the next trip. If you are planning a longer trip, 8 miles or more, it is suggested you add pedaling, hold throttle back 10% and whenever possible allow the bicycle to coast under no power. Coasting under no power is similar to riding a traditional pedal powered bicycle. When riding, a rider will pedal for a few seconds and then stop pedaling, allowing the bike to coast with no power being used. This will greatly enhance your distance between charging.

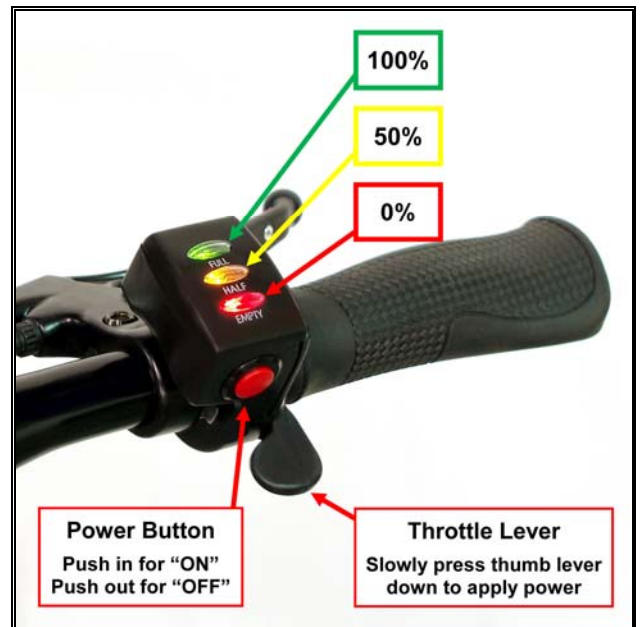

The throttle incorporates an LED battery indicator to assist the rider with determining the amount of charge left in the battery. You should also understand the LED indicators react according to load. There is 1 Green LED, 1 Yellow and 1 Red LED. If the Green LED no longer lights while the bike is not being powered, it is time to recharge the battery. The Green LED does not always represent a fully charged battery though. For example, the Green LED may be lit until a steep incline. As you ride up the incline, you may notice the Green LED will dim as the motor increases the pulling of Amps from the battery. Depending on the load being placed on the motor and/or grades of incline, the green LED dimming represents the accurate battery capacity. Upon the Green LED no longer being lit during riding, particularly under no load, the battery should be charged prior to the next ride. If the Green LED is dimming under light loads, the battery could be under 50% capacity and should be charged. After multiple rides and charges, you will become familiar with the distance per charge available based on your riding style and terrain. For rides close to home with nominal pedaling needed, you should attempt to fully discharge your battery to enhance your understanding on distances per charge.



## Chapter 10: Warranty Service and Repair

Prodeco Technologies has taken great measures in designing and producing your new bicycle to be issue free while offering years of performance. The bicycle however is a mechanical item and an issue can arise. Your bike components are covered for a 2 year period from the date of purchase or within 30 months of the production date, whichever is sooner. The production date is part of your master serial number. Your master serial number can be found on the production label located on the box your bike arrived in or request this number from your dealer. The breakdown of the master serial number is as follows:

### Production Date Master Serial Number Explained

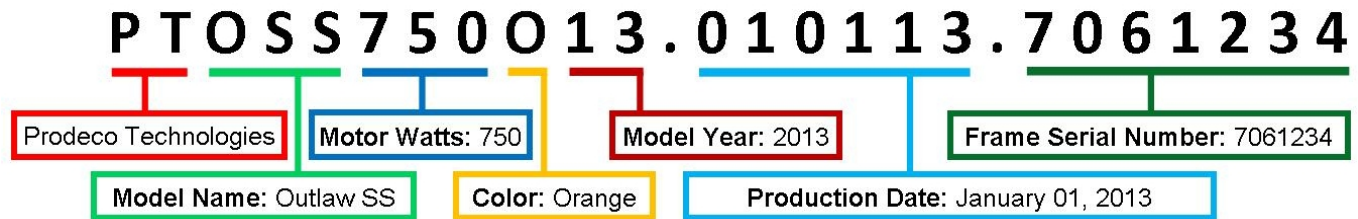

- a. 2 Year limited warranty

010913-B



**Lithium Ion Electric Bicycle**

### 2 YEAR LIMITED WARRANTY

**PRODECO TECHNOLOGIES** warrants this product, including all individual components against defects in material or workmanship as follows:

**PRODECO TECHNOLOGIES LIFETIME FRAME WARRANTY**  
Prodeco bicycle frames are warranted to be free from manufacture defects in materials and/or workmanship for lifetime of the original owner. If the bicycle is sold and/or ownership transferred, the frame warranty will follow Prodeco Technologies' 2 year component warranty.

**PRODECO TECHNOLOGIES LIMITED 2 YEAR COMPONENTS WARRANTY**  
Prodeco Technologies' bicycle components including forks, stem, handlebar, headset, seat post, saddle, brakes, cables, bottom bracket, crank set, pedals, chain, rims, spokes, wheel hub, freewheel, cassette, derailleur, shifter, motor, throttle, controller, wiring harness, kickstand, reflectors and hardware are warranted to be free from manufacture defects in materials and/or workmanship for a 2 year period from the date of original purchase. Electronic components such as controllers, batteries, motors, and chargers may need to be returned to Prodeco Technologies for testing prior to replacement.

**PRODECO TECHNOLOGIES LIMITED 2 YEAR BATTERY WARRANTY**  
Prodeco Technologies' lithium ion LiFEPO4 batteries are warranted to be free from manufacture defects in materials and/or workmanship for a 2 year period from the date of original purchase. The battery warranty does not include damage from power surges, use of improper charger, improper maintenance or other such misuse, or normal wear.

**PRODECO TECHNOLOGIES LIMITED 30 DAY FULL REPLACEMENT WARRANTY**  
If within the first 30 days of purchase, Prodeco Technologies at their sole option and expense will repair or replace any defective Prodeco bicycle upon determining whether the damage, failure, or loss is due to a major defect. Prodeco Technologies or your Prodeco dealer will have sole discretion to determine whether the damage, failure or loss is due to a major defect or otherwise. Warranty claims must be made by the original purchaser by contacting Prodeco Technologies Customer Service Center at 800-943-6190 within the 30 day warranty period. After the initial 30 day period, the registered owner is responsible for shipping costs to Prodeco Technologies of the warranty parts for replacement or repair.

**TERMS OF WARRANTY**  
This warranty only applies to the original registered owner of a Prodeco Technologies bicycle. This warranty does not apply to rental or commercial use bicycles. This warranty is expressly limited to the replacement of defective parts with those of equal or greater value at the sole discretion of Prodeco Technologies. This warranty does not cover any damage or defects resulting from failure to follow instructions in the owner's manual, acts of God, accident, misuse, neglect, abuse, commercial use, alterations, modification, improper assembly, operator error, water damage, stunt riding or improper follow-up maintenance. This warranty does not include normal wear and tear parts (tires, tubes, brake pads). Prodeco Technologies will not be liable and/or responsible for any damage, failure or loss caused by any unauthorized service or use of unauthorized parts. In no event shall Prodeco Technologies be responsible for any direct, indirect or consequential damages, including without limitation, damages for personal injury, property damage, or economic losses, whether based on contract, warranty, negligence, or product liability in connection with their products.

**WARRANTY REMEDY**  
If your Prodeco Technologies electric bicycle is not working properly because of a defect, you may return it to the place of purchase or any authorized Prodeco Technologies dealer for inspection. You may direct your warranty questions to an authorized Prodeco dealer or Prodeco Technologies Customer Service at 800-943-6190. Parts which are verified by Prodeco Technologies to be defective and qualify for warranty replacement will be provided after your warranty claim is processed. Return of the warranted defective part to Prodeco Technologies is the responsibility of the owner. Prior to any warranty replacement, your bicycle must be registered with Prodeco Technologies on our website <http://prodecotech.com/register-your-bike/> or by mailing in the warranty registration card. Proof of purchase in the form of a bill of sale or receipted invoice is required.

This warranty is the sole and exclusive remedy and is in lieu of all other remedies, including consequential and incidental damages. Some states do not allow the exclusion of limitation of consequential damages, so the above limitation or exclusion may not apply to you. This warranty gives you specific legal rights that may vary from state to state.

**SHIPPING TERMS**  
International customers and customers outside of the Continental USA will be subject to all shipping fees, duties and taxes, regardless of location of initial purchase. After 30 days of ownership, shipping charges are the responsibility of all bicycle owners regardless of location for shipping components to Prodeco Technologies or an authorize Prodeco Technologies dealer.



b. Registering your bike

It is very important you register your new bicycle when purchasing. This is the only way your warranty will take effect. It is required you register your bicycle within 2 weeks from the date of purchase. You must save your receipt of purchase. To register your bicycle, you can fill out the form on the Prodeco Technologies website at [www.prodecotech.com](http://www.prodecotech.com) or you can fill out the registration card in the next section below and either scan it to [service@prodecotech.com](mailto:service@prodecotech.com), fax it to 954.974.6729 or mail it to: **Prodeco Technologies, 1201 NE 38<sup>th</sup> Street, Oakland Park, FL 33334**

c. Serial numbers and where to find them

The motor has the serial number written alongside the outside shell. The frame serial number is located under or on top of the crank of the frame. The serial number for the battery is at the back underside right corner.

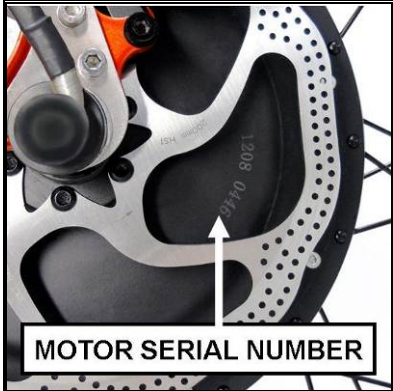

d. Registration Card

### Prodeco Technologies Registration & Warranty Support Form

First Name, Last Name \_\_\_\_\_

Address: \_\_\_\_\_

Suite or Apartment Number: \_\_\_\_\_ (if applicable)

City, State, Zip (Postal) Code: \_\_\_\_\_

Country: \_\_\_\_\_

Email: \_\_\_\_\_

Phone: \_\_\_\_\_

Model Purchased: \_\_\_\_\_

Date Purchased: \_\_\_\_\_

Dealer Purchased From: \_\_\_\_\_

Dealer Location: \_\_\_\_\_

Dealer Phone: \_\_\_\_\_

Dealer Website: \_\_\_\_\_ (if applicable)

Dealer Satisfaction:    1   2   3   4   5   6   7   8   9   10    (10 is excellent)

Sales Person Knowledge: 1   2   3   4   5   6   7   8   9   10    (10 is excellent)

Would You Recommend Dealer: 1   2   3   4   5   6   7   8   9   10    (10 is excellent)

Purchase Satisfaction:    1   2   3   4   5   6   7   8   9   10    (10 is excellent)

Master Serial Number: \_\_\_\_\_ (main box label)

Frame Serial Number: \_\_\_\_\_ (crank bottom bracket)

Motor Serial Number: \_\_\_\_\_ (motor side)

Battery Serial Number: \_\_\_\_\_ (underside of battery)

Spare Battery Serial Number: \_\_\_\_\_ (if applicable)

Primary Use: \_\_\_\_\_

Expected Travel per Month: \_\_\_\_\_ (miles)

e. Part replacement procedure

In the occurrence of a component becoming defective, Prodeco Technologies tries to make part replacement as painless as possible. Simply contact Prodeco Technologies service department and explain the problem. A representative will assist you with getting the part at issue replaced quickly. You can also bring your bicycle to a local authorized dealer and they can assist you with any problem. Parts are always in stock and can be ship immediately. Please refer to Chapter 12: Parts for a list of the parts incorporated into your bicycle.

f. Contacting Prodeco Technologies

You can contact us via the website, email, phone, fax or by mail. Please review the contact details below:

**Website:** [www.prodecotech.com](http://www.prodecotech.com)

**Email:** [service@prodecotech.com](mailto:service@prodecotech.com)

**Phone:** 800.943.6190

**Fax:** 954.974.6729

**Mail:** Prodeco Technologies, 1201 NE 38<sup>th</sup> Street, Oakland Park, FL 33334

## Chapter 11: Specifications

Specifications	
<b>Frame:</b>	Aircraft Grade T6 Aluminum Alloy
<b>Finish:</b>	Candy Orange w/ Clear Coat Protection
<b>Fork:</b>	Double Crown Magnesium Alloy w/ Pre-Load Adjust
<b>Motor:</b>	Prodeco 750W HO Brushless Direct Drive w/ Disc Mount
<b>Battery:</b>	Prodeco LiFePO4 51.2V 9Ah Removable v1.3b
<b>Power:</b>	Thumb Throttle Control
<b>Headset:</b>	CNC'd Aluminum Cups w/ Sealed Bearings
<b>Stem:</b>	Truativ AKA 31.8mm 5° 100mm Aluminum Alloy
<b>Handlebar:</b>	Truativ Riser Aluminum 31.8 x 700mm Length
<b>Front Brake:</b>	Avid Elixir 5 Hydraulic Disc Brake w/ 200mm SS Rotor
<b>Rear Brake:</b>	Avid Elixir 5 Hydraulic Disc Brake w/ 200mm SS Rotor
<b>Brake Levers:</b>	Avid Elixir 5 Hydraulic Disc Brake
<b>Crankset:</b>	SRAM S600 Forged Aluminum 170 Arms w/ 42T
<b>Chain Guard:</b>	SRAM S600 Aluminum Alloy Sandblasted
<b>Bottom Bracket:</b>	Truativ Power Spline Sealed Bearing 68mm English
<b>Pedals:</b>	Truativ Hussefelt Sealed Bearing Platform
<b>Chain:</b>	KMC X8.93 Narrow 1/2" x 3/32"
<b>Front HUB:</b>	Novatec 36H Sealed Bearing 20mm Thru Axle
<b>Rear COG:</b>	DNP Epoch 11-28 8 Speed Nickel Freewheel
<b>Rear Derailleur:</b>	SRAM X9 8 Speed
<b>Shifter:</b>	SRAM XO Twist Grip 8 Speed
<b>Rims:</b>	Stars 12G x 36H Triple Box Aluminum
<b>Spokes:</b>	18-8 Stainless Steel 12G & Solid Brass Nipples
<b>Tires:</b>	Continental Trail King Tire 26" x 2.4"
<b>Tubes:</b>	Kenda 26" X 2.4" 32mm Valve (rear thorn resistant HD)
<b>Kick Stand:</b>	Not Included
<b>Seat Post:</b>	Aluminum 27.2" x 350MM
<b>Seat Post Bracket:</b>	Forged Aluminum Double Barrel Bolt Infinite Adjust
<b>Saddle:</b>	Gyes Genuine Leather
<b>Reflectors:</b>	Catye White Front & Wheels w/ Red Rear
<b>Speed:</b>	25 – 28 MPH
<b>Range:</b>	17 - 20 Miles
<b>Charging Cycles:</b>	2000 +
<b>Charging Time:</b>	4 Hours
<b>Weight Limit:</b>	220 LBS
<b>Frame Warranty:</b>	Lifetime
<b>Components Warranty:</b>	2 Years
<b>Weight:</b>	62 LBS

## Chapter 12: Parts

#	Description	Part Number	MSRP
1	ACCESSORY - BELL - Aluminum - v31 - Thumb Lever - 40mm Diameter - Black Shell	AC.BE.TH.40.B	\$3.95
2	ACCESSORY - TOOL - Multi Use Tool - 18018 - Anodized Red & Nickel	AC.TO.MU.18.RN	\$16.95
3	ACCESSORY - TOOL - Y Tri Hex - 18021 - 4mm, 5mm & 6mm - Black	AC.TO.Y.21.B	\$2.95
4	BATTERY - Prodeco Technologies - LiFePO4 - 51.2V - -- 9Ah -- - v1.3a	PT.BA.LIFE.48V.9A.13A	\$599.95
5	BATTERY CHARGER - 51.2V 2Ah - LiFePO4 - (for 48V Battery)	PT.BC.48V.2A.13A	\$59.95
6	BATTERY MOUNT - Prodeco Technologies - Aluminum & Steel - 34.9mm Mount - v1.3a	PT.BAM.AS.349.LS.13A	\$29.95
7	BATTERY MOUNT PART - Prodeco Technologies - Ignition - v1.3a	PT.BAM.PT.IG.13A.13A	\$8.95
8	BATTERY MOUNT PART - Prodeco Technologies - Mount Cover - (48V) - Left Side - v1.3a	PT.BAM.PT.COV.LL.13A	\$4.95
9	BATTERY MOUNT PART - Prodeco Technologies - Mount Cover - (48V) - Right Side - v1.3a	PT.BAM.PT.COV.LR.13A	\$4.95
10	BATTERY MOUNT PART - Prodeco Technologies - STRUT - 295mm - v1.3a	PT.BAM.PT.STR.295.13A	\$12.95
11	BOTTOM BRACKET - Truvativ - Power Spline - 113mm x 68mm -	PT.BB.TR.PS.113.68	\$20.00
12	BRAKE DISC - Avid Elixir 5 - CALIPER SET - Black - 200 Post Front	PT.BR.AV.E5B.40P.900	\$142.00
13	BRAKE DISC - Avid Elixir 5 - CALIPER SET - Black - 200 IS Rear	PT.BR.AV.E5B.60IS.1350	\$142.00
14	BRAKE DISC - PART ONLY - Avid Elixir - Pad Set - Retail	PT.BR.PT.AV.EL.PR	\$24.95
15	BRAKE LEVER - PART - AVID - Hinge Clamp Only - for Elixir Levers Only - Black	PT.BL.AV.HC.B	\$19.95
16	BRAKE ROTOR - Avid - HS1 - Heat Shedding - 6 Bolt Pattern-Stainless Steel - 200mm	PT.BR.RO.AV.HS1.200	\$55.00
17	CABLE HOUSING - Derailleur - SRAM - Pit Stop - to Size - 1400mm	PT.CAH.DE.SR.PS.1400	\$7.00
18	CASSETTE FREEWHEEL - 8 Speed - DNP Epoch - LY-1108KFN (11-28)	PT.CS.DNP.EP8SP.1128	\$39.95
19	CHAIN - KMC - X 8.93 - 8 Speed - Nickel & Grey - 118L	PT.CH.KMC.X893.118	\$18.95
20	CHAIN PART - KMC - Connector - Missing Link 2 - Black	PT.CH.KMC.CO.ML2.B	\$2.95
21	CRANKSET - PART ONLY - SRAM S600 - Chain Guard ONLY - Black	PT.CR.PT.S600.CG.B	\$24.95
22	CRANKSET - PART ONLY - SRAM S600 - Chain Ring Only - 42T	PT.CR.PT.S600.CR.B	\$12.95
23	CRANKSET - PART ONLY - SRAM S600 - Crank Arm Only - Left Side - Black	PT.CR.PT.S600.CAL.B	\$11.95
24	CRANKSET - PART ONLY - SRAM S600 - Crank Arm Only - Right Side - Black	PT.CR.PT.S600.CAR.B	\$14.95
25	CRANKSET - PART ONLY - Truvativ Crank Bolts - Hex 2 Piece Set	PT.CR.PT.CB.TR.PS	\$3.95
26	DERAILLEUR - SRAM - X9 - Medium Cage - 8/9 Speed - Silver & Black	PT.DE.SR.X9.M89.SB	\$97.00
27	FORK - Suspension - Prodeco 650 - Magnesium - 1 1/8" Threadless - Orange Candy	PT.FO.650.TL26.OC	\$249.00
28	FRAME - Outlaw - V13A - Aluminum - Rigid - Orange Candy	PT.FR.OSS.V13A.OC	\$169.95
29	GRIP SET - Gyes - G-311 - Oversized Leather Rings - 105mm Left / 140mm Right - Black	PT.GR.G.LE311.0540.BK	\$59.95
30	HANDLEBAR - Aluminum - Truvativ - Hussefelt - Mid Rise 40 x 31.8 x 700 - Black Matte	PT.HA.TR.HU.700.BM	\$30.00
31	HEADSET - Threadless - Integrated 44mm - Aluminum CNC - SS Sealed Bearings - Black	PT.HE.TL44.CNC.B	\$49.95
32	HUB - FRONT - NOVATEC DH41SB - 36 x 12G - 20mm Thru Axle Sealed Bearings - Black	PT.HU.FR.NO41.20T.B	\$69.95
33	MOTOR - REAR 26" - Prodeco 48V - 750W - Direct Drive - Black	PT.MO.RR.26.PR48.750.B	\$199.95
34	MOTOR CONTROLLER - Prodeco Technologies - Brushless HALL - 48V - 25A - v1.3a	PT.MC.BH.48.25.13A	\$59.95
35	MOTOR WIRE - Harness - 595mm - Heavy Duty Rear - (for 750W rear drive) - v1.3a	PT.MWH.595.HD.R.13A	\$23.95
36	PEDALS - Truvativ - Hussefelt - Sealed Bearings - Platform w/ Integrated Spikes - Tech Silver	PT.PE.TR.HUS.TS	\$70.00
37	REFLECTOR - Cateye - NGS-272 - Seatpost Bracket - Black	PT.RE.CE.GS272.SPB	\$0.95
38	REFLECTOR - Cateye - RR-165-BSLW - Front Round Reflector - 165mm - White	PT.RE.CE.165.FRW	\$1.95
39	REFLECTOR - Cateye - RR-165-BSLW - Rear Round Reflector - 165mm - Red	PT.RE.CE.165.RRR	\$1.95
40	REFLECTOR - Cateye - RR-530 - Wheel Reflector Set - White	PT.RE.CE.530.WHW	\$2.95
41	RIM TAPE - Kenda - 26" - 25mm Wide - Poly Strips	PT.RI.KE.26.25.P	\$2.95
42	RIM-Aluminum - Stars - 26" - J32M - Triple Box, 36 Holes x 12G - All Black	PT.RI.ST.26.J32.BB	\$39.95
43	SADDLE - GENUINE LEATHER - Gyes ST 17A - 280mm x 170mm - Black	PT.SA.GY.ST17A.BK	\$89.95
44	SEAT CLAMP - CNC Aluminum - Promax 335QX - Frictionless - 31.8mm - Black	PT.SC.PX.335QX.318.B	\$8.95
45	SEATPOST - Aluminum Rigid - Promax SP 271 - 0° Offset - 27.2 x 350 - Black	PT.SP.PX.271.272350.B	\$18.95
46	SHIFTER - SRAM - XO - Twist Grip - 8 Speed	PT.SH.SR.XO.TW.8	\$45.00
47	SPOKE - 12G - 167mm - 18/8 Stainless Steel - Black	PT.SP.12G.167.SS.B	\$0.50
48	SPOKE - 12G - 260mm - 18/8 Stainless Steel - Black	PT.SP.12G.260.SS.B	\$0.50
49	SPOKE NIPPLE - Brass - 12G - 16mm	PT.SP.NI.BR.12G.16	\$0.50
50	STEM - Aluminum - Truvativ - AKA - 5° x 100mm x 1 1/8" - Black Matte	PT.ST.TR.AKA.100.BM	\$45.00
51	THROTTLE - Wux - THUMB - Battery Led Indicator - w/ On & Off Push Button - 48V	PT.TH.WX.15.16.48V	\$18.95
52	TIRES - Continental - Trail King - 26" x 2.4"	PT.TI.CO.TK.26.24	\$34.95
53	TUBES - Kenda - 26" - 2.4" - Heavy Duty - 32mm Valve (front)	PT.TU.KE.26.240.32	\$8.95
54	TUBES - Kenda - 26" - 2.4" - Heavy Duty Thorn Resistant - 32mm Valve (rear)	PT.TU.KE.26.240H.32	\$14.95